

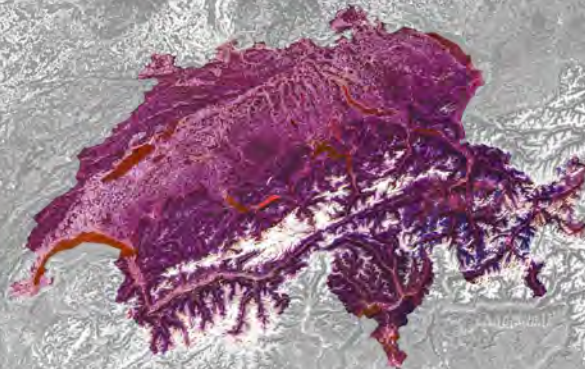

swiss
space center

MEMBERS' PROFILES

December 2018





MEMBERS' PROFILES

December 2018

Cover Illustrations :

SWITZERLAND, contains modified Copernicus Sentinel data (2016), processed by GeoVille and modified by SSC, CC BY-SA3.0 IGO

Switzerland as seen by Envisat (2006), ©ESA and modified by SSC, CC BY-SA3.0 IGO

<https://creativecommons.org/licenses/by-sa/3.0/igo/>

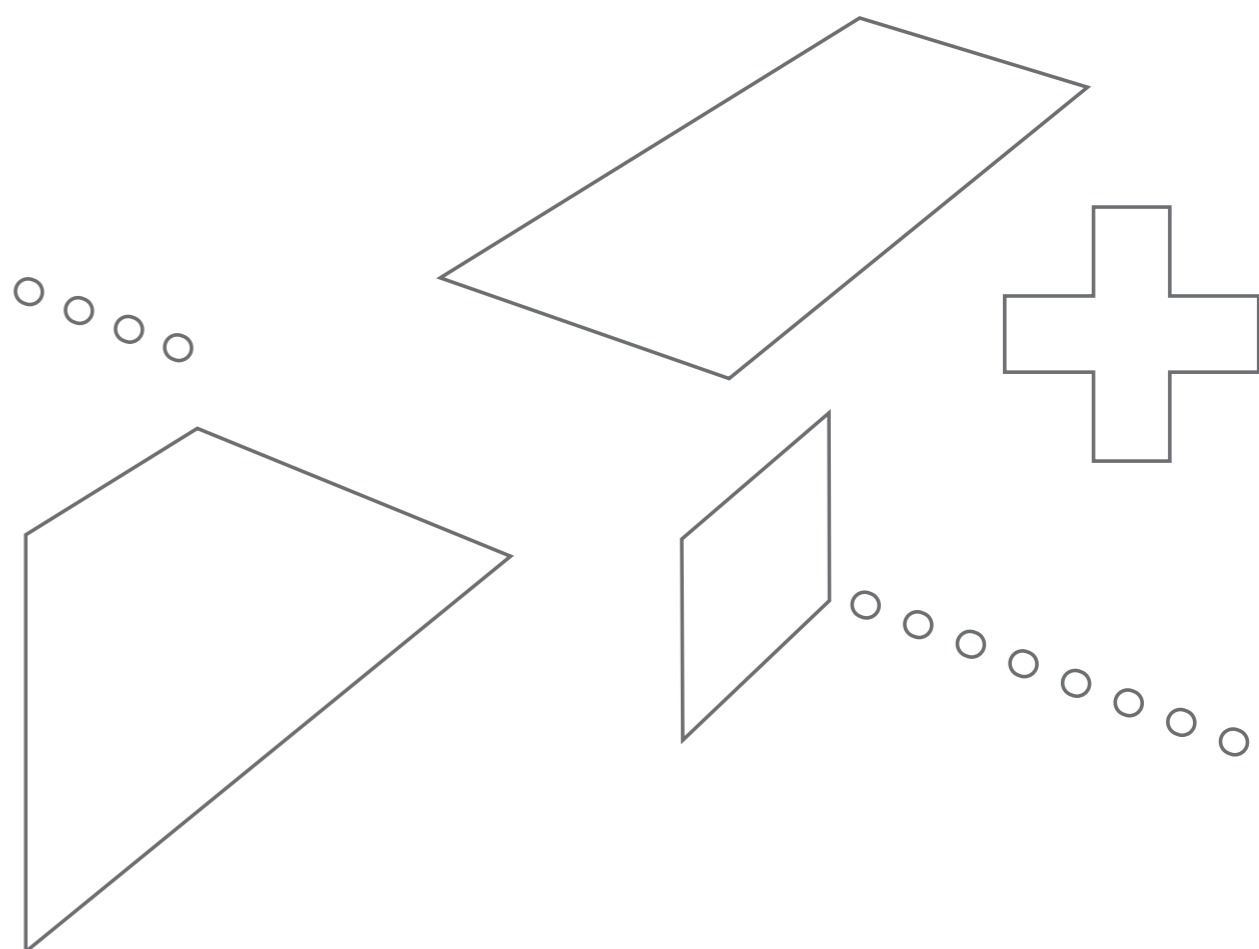

Table of Contents

5 Introduction

7 Industry

31 Research

39 Academia

INTRODUCTION

You have in your hands the second edition of the brochure presenting the capabilities and competences of the Swiss Space Center (SSC) members. Officially recognized as a truly national entity in 2012 by the Swiss Space Office from the State Secretariat for Education, Research and Innovation (SERI/SSO), the Swiss Space Center supports the SERI/SSO in the implementation of the Swiss Space Policy on specific tasks by:

- networking Swiss actors at national and international level,
- facilitating access to space projects for established actors and for newcomers,
- providing education and training,
- promoting public awareness of space.

At the time of this second edition (December 2018) the SSC has 37 members throughout Switzerland, among which 22 industries, 9 universities and 4 Research and Technology Organisations (RTO). In addition, the European Center for Nuclear Research (CERN) based in Geneva signed a partnership agreement with the SSC in 2016.

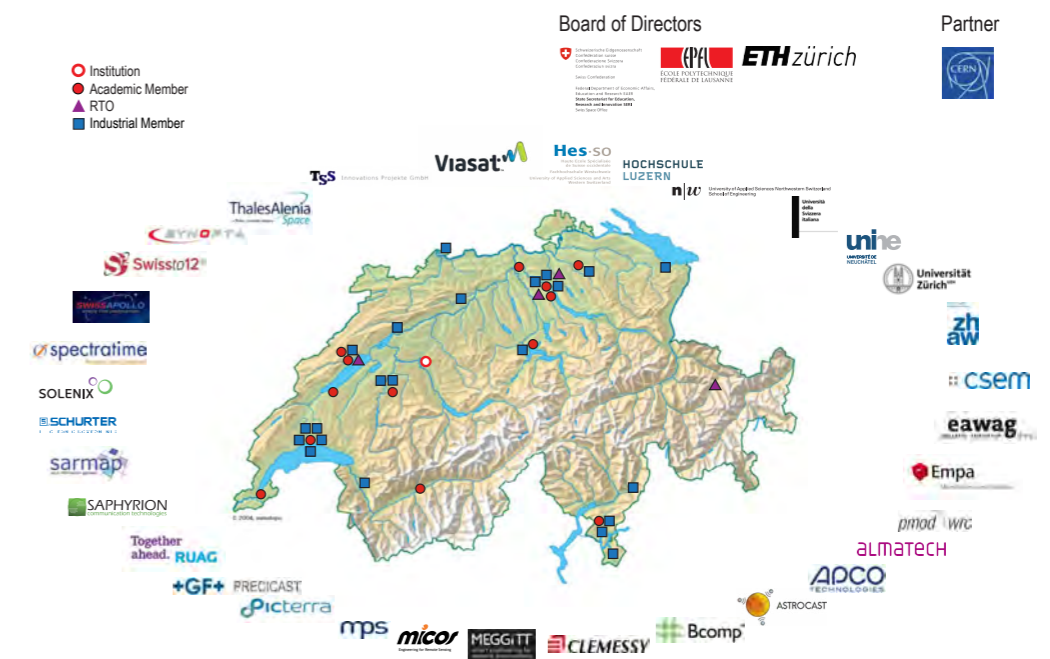

We hope you will discover in more details what our members have to offer you in terms of expertise, products and potential collaborations. You may contact them directly or via the Swiss Space Center. Please note that all the information within this brochure were provided by the entities and reflect the situation in 2018.

INDUSTRY

Segment	Research	Development	Production
Earth Observation			
Life and Physical Sciences			
Satellite-based Applications			
Instruments and Payloads	✓	✓	✓
Spacecraft and on-board Equipment	✓	✓	✓
Ground Segment		✓	✓
Materials and Processes	✓	✓	✓
Structures	✓	✓	✓
Electronic Components			
Software			
Basic Research for Space Technology	✓	✓	✓
Small Satellite Activities	✓	✓	

ALMATECH SA

“Space and Naval Engineering”

References

- FLEX Calibration Unit
- SVOM MXT Instrument Structure
- CHEOPS Telescope Optical Structure
- Sentinel-5 instrument Structure and Radiators
- Solar Orbiter Slit Change Mechanism (SCM) of the SPICE instrument
- Solar Orbiter Attenuator Mechanism (ATM) of the STIX instrument
- Exomars 2020 Carrier Module MLI and its support structure
- Metop-SG SAS MLI and MLI fixation
- Etc

Profile

Almatech is a privately-held Swiss SME specialized in the design, engineering and MAIT of ultra-stable structures, high-precision mechanisms and thermo-optical hardware for the European space market.

Since its inception in 2009, Almatech contributed to multiple ESA missions such as PREMIER, Bepi Colombo, Solar Orbiter, Sentinel-5, CHEOPS, Exomars 2020 and Metop-SG including numerous successful hardware deliveries.

Almatech engineering competencies range from inventive concept definition through top-notch structural and thermal analyses to the final delivery of fully-tested flight hardware.

Field of Expertise

- Structural and thermal analysis
- High-precision mechanisms
- Compliant systems
- Lightweight Structures
- Ultra-stable CFRP Structures
- Exotic materials and processes
- Multi-layer insulation (MLI)
- Thermo-optical coatings

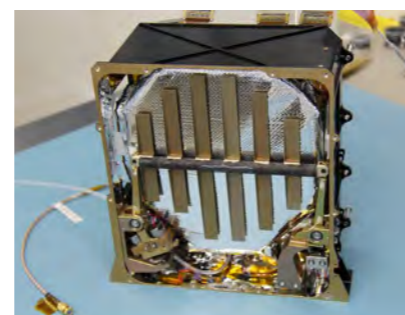
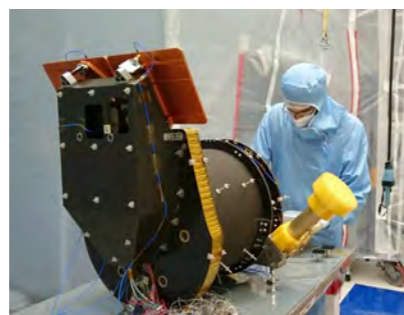

almatech

ALMATECH SA

EPFL Innovation Park D
CH - 1015 Lausanne
Tel: +41 (0) 21 555 30 00
info@almatech.ch
www.almatech.ch

Segment	Research	Development	Production
Earth Observation	✓	✓	✓
Life and Physical Sciences			
Satellite-based Applications			
Instruments and Payloads	✓	✓	✓
Spacecraft and on-board Equipment	✓	✓	✓
Ground Segment	✓	✓	✓
Materials and Processes	✓	✓	✓
Structures	✓	✓	✓
Electronic Components			
Software			
Basic Research for Space Technology			
Small Satellite Activities	✓	✓	✓

APCO Technologies SA

“We take up technical challenges.”

Profile

APCO Technologies is specialized in the development of high quality mechanical and electro-mechanical equipment for the Space (Satellites and Launchers), Energy and Industry domains including project management, design, production, testing, installation, operation and on-site support. APCO Technologies is certified EN 9100, ISO 9001, ISO 14001, ISO 27001, OSHAS 18001. APCO Technologies is employing more than 350 highly qualified people in Switzerland, France and French Guiana.

Field of Expertise

- Launcher and Spacecraft Structures (metallic and composite)
- Spacecraft Instrument Structures and Mechanisms
- Spacecraft Instruments
- Launcher and Spacecraft Mechanical Ground Support Equipment for Integration, Positioning, Hoisting, Handling and Testing
- Launcher and Spacecraft containers
- Infrastructures and Transfer Utilities
- Services at the European Space Port in French Guiana (Operations and maintenance of the Payload Preparation Facilities, Mechanical Group within the Technical Office and responsible of the Individual Protection Equipment)

References

- Galileo, Sentinel-1/2/3/4/5/6, Bepi-Colombo, Exomars, IXV, Solar Orbiter, Eurostar, MTG, Euclid, CSO, MPCV, MetOp-SG MGSE
- Ariane 6 MGSE Center of Excellence
- Ariane 6 Boosters Upper & Lower Attachments
- Soyuz and Ariane 5 Transfer Systems
- Smart-1, Proba-2, Sentinel-5 P, MTG and Triton S/C Structures
- Sentinel-2 MSI, -3 OLCI and SLSTR Instr. Structure, Harness & Thermal S/S

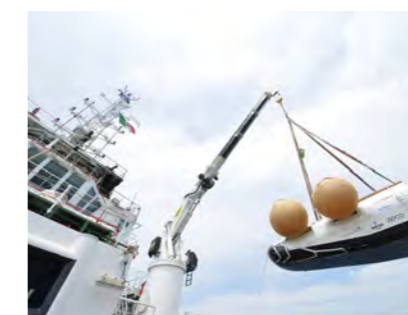
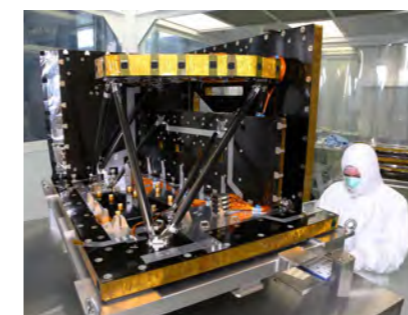

APCO TECHNOLOGIES

APCO Technologies SA

Chemin de Champex 10
CH - 1860 Aigle
Tel: +41 (0) 24 468 98 00
aigle@apco-technologies.eu
www.apco-technologies.eu

Segment	Research	Development	Production
Earth Observation			
Life and Physical Sciences			
Satellite-based Applications	✓	✓	✓
Instruments and Payloads		✓	
Spacecraft and on-board Equipment	✓	✓	✓
Ground Segment		✓	
Materials and Processes			
Structures	✓	✓	
Electronic Components		✓	
Software		✓	✓
Basic Research for Space Technology			
Small Satellite Activities	✓	✓	✓

Astrocast SA

“Global low-cost connectivity for IoT applications”

References

Astrocast engineers have expertise in Space electronics, IoT applications and CubeSat development that include:

- Space electronics design (ECSS standard)
- Orbit analysis
- Attitude control systems design
- Communication system design
- Satellite operations
- Space and ground software development
- Mechanical design and analysis
- Testing and qualification of COTS components for space applications

Profile

Astrocast, in partnership with the European Space Agency, Airbus and Thuraya, is developing an advanced Nanosatellite network for the Internet of Things (IoT). Airbus and Astrocast have developed a low-cost ASIC and module that provide the most power efficient satellite modem for IoT applications. Thuraya has provided L-band spectrum and a global network of distributors and integrators for sales and support of our service. The constellation will consist of 64 CubeSat in Low Earth Orbit (LEO) and will provide low latency global coverage.

Field of Expertise

- ESA's Advanced Research in Telecommunications Systems (ARTES) funding to develop an IoT nanosatellite network;
- DARA instrument digital board: Development and Manufacturing of the processing unit onboard Proba3
- Development of a CubeSat High-speed Communication System
- CHEOPS: Supporting the development of ground segment software
- xTerm (MdP): Advancements in L-band terminal up to TRL4 in partnership with IICT, Yverdon
- CTI – Antennas for CubeSat Communications in partnership with EPFL-MAG

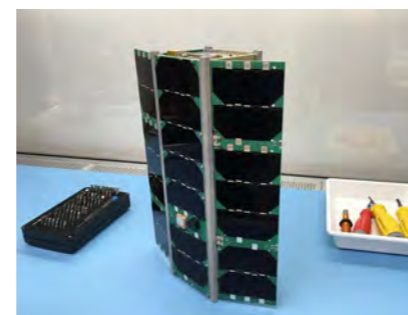

Astrocast SA

EPFL Innovation Park
Ch. de la Dent d'Oche 1B
CH - 1024 Ecublens
Tel: +41 (0) 22 575 30 10
info@astrocast.net
www.astrocast.net

Segment	Research	Development	Production
Earth Observation			
Life and Physical Sciences			
Satellite-based Applications	✓	✓	
Instruments and Payloads			
Spacecraft and on-board Equipment			
Ground Segment			
Materials and Processes	✓	✓	✓
Structures	✓	✓	
Electronic Components			
Software			
Basic Research for Space Technology			
Small Satellite Activities	✓	✓	

Bcomp

“Superior composite materials from natural fibres”

Profile

Bcomp develops natural fibre composite solutions, substituting existing engineering materials (carbon fibre composites, glass fibre composites, but also aluminium or wood), cutting weight and cost.

In only 5 years, Bcomp has established itself as a renowned supplier of high-performance, sustainable materials supplier in the Sports & Leisure industry, developing proprietary lightweight solutions made from renewable materials. Thanks to its innovative products and strong brands, the company has built a large international customer portfolio in the Sports & Leisure industry, and more recently in the Mobility, Design and Aerospace industries.

Field of Expertise

- Design, fabrication and testing of composite structures, with natural and/or synthetic fibers
- Bcomp offers technology to build thin shell structures with unrivaled flexural stiffness to weight ratio and high vibration damping

References

- Swiss Space Center mandate to develop novel lightweight composite structures for space applications for ESA.
- SSO MDP 2014 in collaboration with FHNW. In depth damping characterization of natural fiber composite structures for space applications.
- Development of interior automotive parts with several automotive brands
- Car body parts for Electric GT Championship

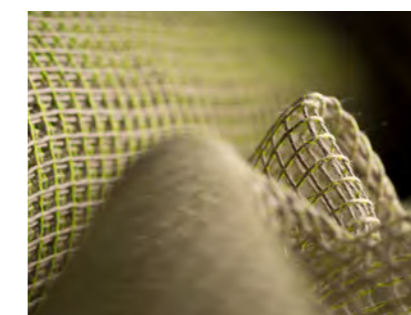
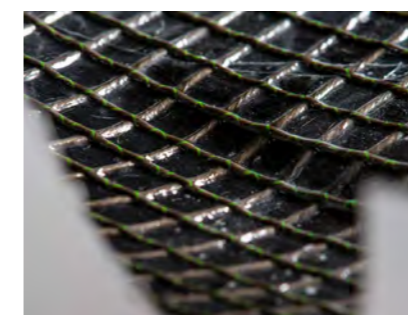

Bcomp

Passage du Cardinal 1
CH - 1700 Fribourg
Tel: +41 (0) 26 558 84 02
contact@bcomp.ch
www.bcomp.ch

Segment	Research	Development	Production
Earth Observation			
Life and Physical Sciences			
Satellite-based Applications			
Instruments and Payloads			
Spacecraft and on-board Equipment			
Ground Segment		✓	✓
Materials and Processes			
Structures			
Electronic Components		✓	✓
Software		✓	✓
Basic Research for Space Technology			
Small Satellite Activities			

Clemessy Switzerland AG

“Custom-made simulators and EGSE for spacecraft builders”

References

- MeteoSat Third Generation: EGSE for platform validation, for FCI instrument validation and IA-DEA instrument validation
- ExoMars: EGSE for 2016 and 2020 missions, covering platform of the spacecrafts, Rover Module and Carrier Module

Profile

Clemessy Switzerland designs, integrates, develops and delivers electrical ground support equipment for monitoring and control systems, for aeronautics and space, transport infrastructures, scientific end environment.

Field of Expertise

- Electrical ground support system: Solar array simulator, battery simulation and load simulation
- Monitoring and control system
- Test stands
- Maintenance and operations



Clemessy Switzerland AG

Gueterstrasse 86b
CH - 4053 Basel
Tel: +41 (0) 61 205 31 50
cys.ch@clemessy.com
www.clemessy.ch

Segment	Research	Development	Production
Earth Observation			
Life and Physical Sciences			
Satellite-based Applications	✓	✓	✓
Instruments and Payloads	✓	✓	✓
Spacecraft and on-board Equipment	✓	✓	✓
Ground Segment	✓		
Materials and Processes			
Structures			
Electronic Components			
Software	✓		
Basic Research for Space Technology			
Small Satellite Activities			

MEGGITT SA

“Smart engineering for extreme environments”

Profile

Meggitt PLC is an international group operating in North America, Europe and Asia. Known for its specialised extreme environment engineering, Meggitt is a world leader in aerospace, defence and energy. Meggitt employs approximately 12,000 people at over 40 manufacturing facilities and regional offices worldwide. Meggitt SA – trading as Meggitt Sensing Systems Switzerland – has become worldwide recognised as a leading supplier of high-performance and high reliability sensing and monitoring systems measuring physical parameters in the extreme environments.

Field of Expertise

- Piezo-electric transducers
- Vibration and dynamic pressure transducers
- Our systems measure displacement, relative and absolute vibration, rotational speed and dynamic pressure for space applications
- Meggitt's sensors withstand temperatures from -253°C to +780°C, pressures up to 350 bar and vibration up to 10,000g
- Meggitt's sensors use the eddy current measurement principle

References

Meggitt has been designing systems for space applications since the early 1970s, including high-performance vibration and dynamic pressure transducers and electronics for launchers and satellites. Meggitt's instrumentation further supported the development of the Vulcain and Vulcain 2 engines of the Ariane 5 launcher. Many of Meggitt's systems are flight qualified for Ariane 5.



MEGGITT SA

Rte de Moncor 4
CH - 1701 Fribourg
Tel: +41 (0) 26 407 11 11
www.vibro-meter.com

Segment	Research	Development	Production
Earth Observation		✓	✓
Life and Physical Sciences		✓	✓
Satellite-based Applications			
Instruments and Payloads	✓	✓	✓
Spacecraft and on-board Equipment			
Ground Segment	✓	✓	
Materials and Processes			
Structures			
Electronic Components			
Software	✓		
Basic Research for Space Technology	✓	✓	
Small Satellite Activities		✓	

Micos Engineering GmbH

“Engineering for Remote Sensing”

References

Contribution to European programmes:

- MTG Calibration Black Bodies and IRS Spectral Calibration Algorithm
- Sentinel-4 AIT-OGSE
- Sentinel-5 Calibration Subsystem
- Proba-3 FFLS Opto-Mechanical Subsystem
- MetOp 3MI Calibration M- and EGSE, METImage ReImager

Products development:

- Miniaturized Aerosols Monitoring Nephelometers
- High Accuracy Optical Encoders
- Waveguide based High Resolution Spectrometers

Profile

Micos Engineering GmbH is an independent system engineering SME that focuses on optical instrumentation for the European space market. Micos serves its customers with design, engineering and AIT of ground support equipment and flight hardware.

Micos facilities dedicated to integration and testing account for ISO5, ISO6 and ISO7 cleanroom areas equipped with quality and metrology instrumentation to support opto-mechanical integration and verification; TVAC facility with double cooling circuit; optical laboratory for breadboarding activities; thermometry calibration and vibration monitoring equipment are also in-house.

Field of Expertise

Our multi-disciplinary team runs projects with a professional network of industrial and institutional partners. Micos key competences:

- Optical, Opto-Mechanical Design and AIT
- Characterization & Calibration Systems and GSEs
- Optical fibre based Metrology Systems
- Spectroscopic and Interferometric Systems
- Prototype Processing and Algorithms
- Project and Subcontractor Management, Product Assurance

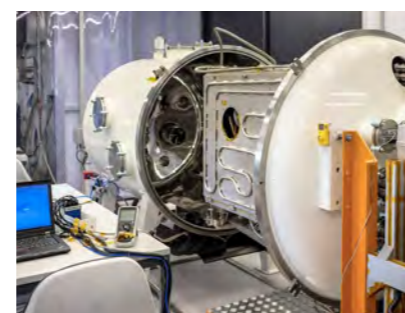

Micos Engineering GmbH

Überlandstrasse 129
CH - 8600 Dübendorf
Tel: +41 (0) 44 533 80 00
micos4u@micos.ch
www.micos.ch

Segment	Research	Development	Production
Earth Observation			
Life and Physical Sciences			
Satellite-based Applications		✓	✓
Instruments and Payloads		✓	✓
Spacecraft and on-board Equipment			
Ground Segment			
Materials and Processes			
Structures			
Electronic Components			
Software			
Basic Research for Space Technology			
Small Satellite Activities			

MPS

“Solutions in microspace”

Profile

MPS Microsystems develops and manufactures high-precision, high-performance and very low-friction electro-mechanical microsystems.

Managing the miniaturisation and integration of functions in small spaces, MPS Microsystems provides solutions that meet specific customer requirements. MPS Microsystems also offers a standard range of products, such as linear bearings and ball screws under the “micro-linea” trademark. Located in Bienne, Switzerland, in a modern and well equipped facility MPS Microsystems provides customers with unique capabilities that are perfectly suited to the requirements of the high-tech sectors.

Field of Expertise

- Miniature highly accurate ballscrews
- Miniature linear ball bearings
- Custom made complex and highly accurate electromechanical systems
- Miniature active optical systems such as zoom and laser focus mechanisms



MPS Micro Precision Systems AG

Chemin du Long-Champ 95
CH - 2504 Biel-Bienne
Tel: +41 32 344 43 00
info@mpsag.com
www.mpsag.com

Segment	Research	Development	Production
Earth Observation			✓
Life and Physical Sciences			
Satellite-based Applications	✓	✓	✓
Instruments and Payloads			
Spacecraft and on-board Equipment			
Ground Segment			
Materials and Processes			
Structures			
Electronic Components			
Software		✓	✓
Basic Research for Space Technology			
Small Satellite Activities			

Picterra

“User-Sourced Artificial Intelligence For Earth Imaging”

References

Picterra has been awarded the VI-TUS project in the frame of the CAL-L4IDEAS 2017, which investigates the unmixing of Sentinel-2 imagery supported by aerial data for vine vitality mapping at high temporal resolution.

Profile

Picterra develop Artificial Intelligence (AI) systems dedicated to the processing and exploitation of aerial and satellite imagery. Picterra's team cumulates thirty years of experience in the application of AI in the processing of Earth observation imagery. Picterra aims at democratizing the usage of such images via an interactive platform, where each user can develop and manage its own AI. Partnering human expertise and knowledge with the power of AI, bring new geo-spatial insights on our Planet as well as human activities such as monitoring infrastructures, socio-economic or environmental indicators.

Field of Expertise

- Earth observation satellite imagery processing (optical, SAR)
- Very high resolution aerial image processing
- Machine learning including deep learning, transfer learning, anomaly and change detection
- Cloud software engineering
- GIS expertise



Picterra
 Av. de Jurigoz 11
 CH - 1006 Lausanne
 Tel: +41 (0) 76 612 79 25
 contact@picterra.ch
 www.picterra.ch



Segment	Research	Development	Production
Earth Observation			
Life and Physical Sciences			
Satellite-based Applications			
Instruments and Payloads		✓	
Spacecraft and on-board Equipment		✓	
Ground Segment			
Materials and Processes		✓	✓
Structures		✓	✓
Electronic Components			
Software			
Basic Research for Space Technology			
Small Satellite Activities			

Precicast Additive SA

“Additive Manufacturing for Aerospace Solutions - Your Partner for AM Engineering Services”

Profile

The deep metallurgical know-how of GF Precicast finds a new expression in GF Precicast Additive, founded in November 2016. The potential of its additive technologies, enabling design freedom, complex lattice structures, lighter parts with integrated functions directly from the 3D model, quickly and with reduced costs, add to the expertise and qualified resources of the company customize services with high value in 3D metal printing integrated with investment casting.

Field of Expertise

- GF Precicast Additive proposes as partner for the development of
- Innovative solutions along the entire supply chain, from co-design to direct
- Manufacturing of metal parts through Laser PBF and Electron Beam PBF, from Research & Development of new materials, to post-processing, up to quality inspections.

References

- Turbo pumps for liquid space propulsion in nickel base alloy
- Structural parts in aluminum and titanium alloy



+GF+ PRECICAST

GF Precicast Additive SA
 Via Gaggiolo 27
 CH - 6855 Stabio
 Tel: +41 (0) 91 695 77 11
 info.GFPrecicastAdditive@georgfischer.com
 www.GFPrecicast.com

Segment	Research	Development	Production
Earth Observation		✓	✓
Life and Physical Sciences			
Satellite-based Applications		✓	✓
Instruments and Payloads		✓	✓
Spacecraft and on-board Equipment		✓	✓
Ground Segment			
Materials and Processes	✓	✓	✓
Structures	✓	✓	✓
Electronic Components	✓	✓	✓
Software		✓	✓
Basic Research for Space Technology	✓	✓	✓
Small Satellite Activities	✓	✓	✓

RUAG Space

“Together Ahead.”

References

- Development and manufacturing of payload fairings for the Ariane, Vega and Atlas programs
- Providing satellite structures and dispensers for OneWeb - aiming to secure global broadband internet service

Profile

RUAG Space is the number one independent space product supplier and the leading supplier of products for the space industry in Europe, with a growing presence in the United States. Experience, outstanding reliability, customer focus and a comprehensive, clearly structured product portfolio all make RUAG Space the partner of choice for manufacturers of satellites and launchers. The skills and services RUAG offers cover all the essential aspects of space projects, ranging from mission analysis, systems engineering and project management through engineering services, assembly and integration, to support and testing at the launch site.

Field of Expertise

- Launcher Structures & Separation Systems
- Satellite Structures, Mechanisms & Mechanical Equipment
- Digital Electronics for Satellites and Launchers

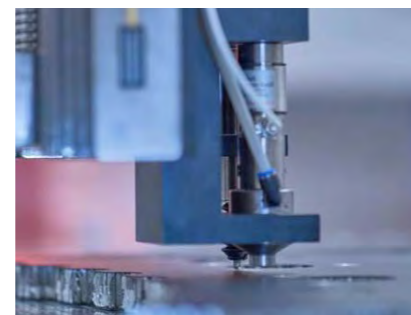

Together ahead. RUAG

RUAG Space

Ruag Schweiz AG
Schaffhauserstrasse 580
CH - 8052 Zürich
info.space@ruag.com
www.ruag.com

Segment	Research	Development	Production
Earth Observation	✓	✓	
Life and Physical Sciences			
Satellite-based Applications	✓	✓	✓
Instruments and Payloads	✓	✓	✓
Spacecraft and on-board Equipment		✓	✓
Ground Segment	✓	✓	✓
Materials and Processes	✓		
Structures			
Electronic Components	✓	✓	✓
Software		✓	✓
Basic Research for Space Technology	✓	✓	
Small Satellite Activities			

Saphyrion Sagl

“Space-qualified integrated circuits and GNSS data processing instruments”

Profile

Saphyrion Sagl, located in Bioggio (Ticino), is key player in the industry domain of space-borne RF, analog and mixed mode electronics, and its enabling technology allowed the European Space Agency to pioneer compact GNSS receivers for satellite orbit control and other scientific applications. SAPHYRION developed a solid background in signal processing and systems and subsystems for ground applications, like high performance GNSS systems and laboratory instruments for GNSS data acquisition and processing.

Field of Expertise

- Design of radiation-hardened integrated circuits (RF, analog and digital logic):
- Processing of signals in different bands (L, S, X, K)
 - Electronic for RF and analog stages of space-borne telecom equipment
 - Advanced instrumentation for GNSS integrity monitoring
 - GNSS data processing and software defined GNSS receivers
 - Data fusion (GNSS/IMU, GNSS/UWB and others) for hybridized platforms
 - Consultancy in IC design and signal processing

References

- ASICs for space-borne GNSS receivers on all recent ESA Earth Observation missions: Sentinel, Swarm, Earthcare, Metop
- Strategic partnership in European-based GNSS receiver production with: RUAG Space, Airbus Defense & Space, Thales Alenia Space
- Wide experience partnering or coordinating ESA and EU-funded projects with large enterprises, academies, research centers, SMEs, end users and integrators.

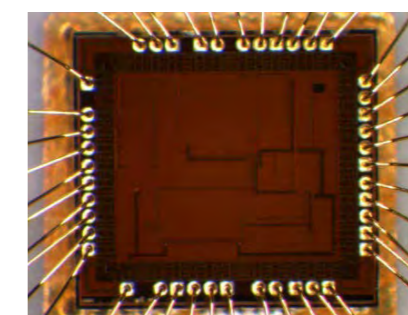
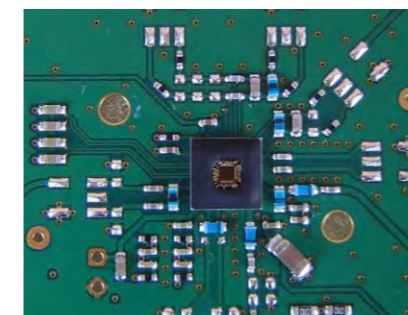

SAPHYRION
communication technologies

Saphyrion Sagl

Strada Regina 16
CH - 6934 Bioggio
Tel: +41 (0) 91 220 11 00
contact@saphyrion.ch
www.saphyrion.ch

Segment	Research	Development	Production
Earth Observation	✓	✓	✓
Life and Physical Sciences			
Satellite-based Applications	✓	✓	✓
Instruments and Payloads			
Spacecraft and on-board Equipment			
Ground Segment			
Materials and Processes			
Structures			
Electronic Components			
Software	✓	✓	✓
Basic Research for Space Technology			
Small Satellite Activities			

sarmap SA

“The Earth Observation gateway”

References

- Partner in the ESA-sponsored IAP TransparentForests project, to strengthen quality and transparency in the forest certification process.
- Partner of the SDC-sponsored Remote sensing-based Information and Insurance for Crops in Emerging economies (RIICE) project, aiming to reduce the vulnerability of rice smallholder farmers in low-income countries in Asia.
- Developing SARscape, an end-to-end state-of-the-art software processing chain for generating SAR-based products for different applications.

Profile

sarmap's mission is to build and provide an innovative, sophisticated yet simple remote sensing software products and services, dedicated to the generation of digital information for a better management and risk assessment of Earth's natural/environmental resources. sarmap is a Swiss company founded as spin-off of the University of Zurich. While being at the forefront of technology, it builds on traditional values such as reliability and long-term collaboration partnerships based on mutual trust and respect.

Field of Expertise

Spaceborne / Airborne monitoring solutions for:

- Topography
- Land Displacement
- Agriculture and food security
- Flooding
- Forestry and forest certification
- Change Detection



sarmap SA
 Cascine di Barico 10
 CH - 6989 Purasca
 Tel: +41 (0) 91 600 93 65
 sarmap@sarmap.ch
 www.sarmap.ch

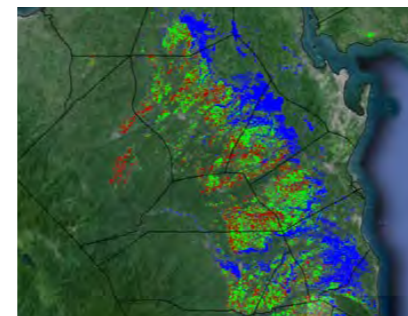
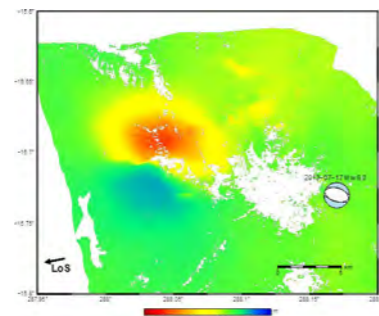

Segment	Research	Development	Production
Earth Observation			
Life and Physical Sciences			
Satellite-based Applications			
Instruments and Payloads			
Spacecraft and on-board Equipment			
Ground Segment			
Materials and Processes			
Structures			
Electronic Components	✓	✓	✓
Software			
Basic Research for Space Technology			
Small Satellite Activities			✓

SCHURTER

“Safety is our Business”

Profile

SCHURTER is an internationally leading innovator and manufacturer of electric and electronic components. The company focuses on safe power supply and easy-to-use equipment. Its extensive product portfolio comprises standard solutions in the fields of circuit protection, plugs and connectors, EMV products, switches, input systems and electronic manufacturing services. SCHURTER's global network of representative offices ensures reliable delivery and professional customer service. Where standard products are unsuitable, the company develops client-specific solutions.

Field of Expertise

SCHURTER is proud to meet standards such as defined in the ESA Internal Requirement Definitions or in Military Standards (e.g. MIL, NF, NNO, GAM T1) and Aviation Standards.

- we focus on the safety for power systems
- we develop customer specific fuse designs for over-current protection under extreme conditions
- we guarantee that the certification of our products, the manufacturing and the logistics are audited regularly
- we ensure a product lifetime of up to 30 years and a documented life cycle as well as lifelong information

References

SCHURTER is the sole European supplier of qualified fuses by the ESA. The cooperation has led to two products for protecting electronic modules in aerospace applications:

- MGA-S, a surface mount fuse for space application
- HCSF, a solid state, thin film, surface mount fuse for high current space application



SCHURTER
 ELECTRONIC COMPONENTS

SCHURTER
 Werkhofstrasse 8-12
 CH - 6002 Lucerne
 Tel: +41 (0) 41 369 31 11
 contact@schurter.ch
 www.schurter.com/space

Segment	Research	Development	Production
Earth Observation		✓	✓
Life and Physical Sciences			
Satellite-based Applications		✓	✓
Instruments and Payloads			
Spacecraft and on-board Equipment			
Ground Segment	✓	✓	✓
Materials and Processes			
Structures			
Electronic Components			
Software	✓	✓	✓
Basic Research for Space Technology			
Small Satellite Activities			

Solenix GmbH

“Engineering Inspiration”

References

- Überlog is an operations logbook solution for tracking events and activities, used daily by major satellite operators.
- Elveti is an easy to use, flight-proven mission control system designed to operate both single and constellations of nano & small satellites. It is the baseline mission control system for QB50.
- We evolve and maintain critical ground segment systems for ESA and EUMETSAT.

Profile

Solenix is an international space company offering high-quality software engineering services, operations and consultancy services, and software products. We develop innovative solutions to complex problems, combining state-of-the-art technology with proven and established practices. We are well known for being a reliable, capable and flexible partner. Our customers are European space agencies and satellite operators.

Solenix consists of the Swiss Solenix GmbH and its subsidiaries Solenix Deutschland, Solenix Italia and Solenix Schweiz. The group employs 35 staff distributed over the different places of business.

Field of Expertise

Development of distributed software systems with focus on mobile and web applications:

- End-to-End System & Service Monitoring
- Electronic Event Logging, Alarming & Processing
- Intelligent Planning, Scheduling and Optimisation
- Earth Observation End-to-End Processing Chains
- Mission Monitoring & Control Systems
- Robotics & Automation Control Systems
- Mission Data Analysis & Visualisation

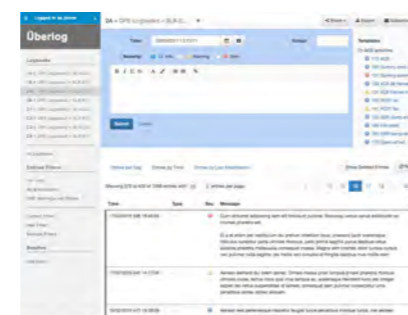
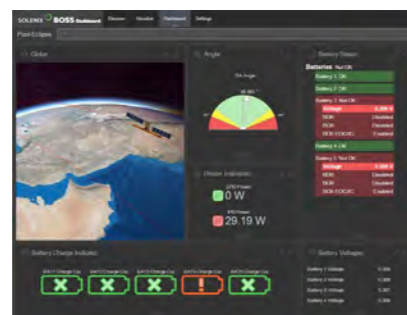

Solenix GmbH
 Bornstrasse 3
 CH - 4616 Kappel
 Tel: +41 (0) 62 216 35 02
 info@solenix.ch
 http://solenix.ch

Segment	Research	Development	Production
Earth Observation			
Life and Physical Sciences			
Satellite-based Applications		✓	✓
Instruments and Payloads		✓	✓
Spacecraft and on-board Equipment		✓	✓
Ground Segment		✓	✓
Materials and Processes			
Structures			
Electronic Components		✓	✓
Software		✓	✓
Basic Research for Space Technology			
Small Satellite Activities			

Spectratime

“iPrecision Timing Solutions®”

Profile

Founded in 1995 in Neuchâtel, Switzerland, Spectratime designs, manufactures and markets a full range of high-performance, low-cost crystal, rubidium and maser sources, smart integrated GPS or GNSS reference clocks, and clock testing systems. Its products are used in a wide variety of applications, including telecommunications, defense, navigation, instrument, broadcasting, and space. The company is a recognized leader in the industries it serves and distributes its products globally through Spectratime’s sales offices in Europe, Asia, and United States.

Field of Expertise

- High-performance crystal, rubidium & maser clocks
- Commercial & rugged military rubidium oscillator sources
- Space crystal, rubidium and maser clock sources
- GPS/GNSS synchronized crystal and rubidium clocks
- Integrated, low noise GPS/GNSS rubidium reference standards
- High-resolution ADEV clock analyzers
- Time & frequency clock experts

References

Spectratime is the world’s largest manufacturer of Swiss-made space atomic clocks with over 100 clocks flying onboard space satellites around the earth, providing the high-precision “heart beat pulse” for the land, sea and air operations of positioning, navigation and timing applications. The company supplies atomic clocks for the following major space GNSS and other satellite communications programs:

- Beidou
- Galileo
- IRNSS
- GAIA
- GAGAN
- METOP

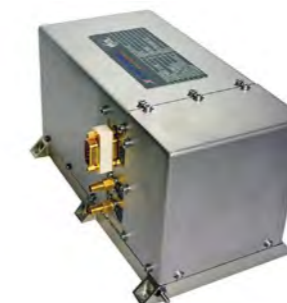

Spectratime
 Orolia Switzerland SA
 Rue du Vauseyon 29
 CH - 2000 Neuchâtel
 Tel: +41 (0) 32 732 16 66
 space@spectratime.com
 www.spectratime.com

Segment	Research	Development	Production
Earth Observation			
Life and Physical Sciences		✓	
Satellite-based Applications			
Instruments and Payloads			
Spacecraft and on-board Equipment			
Ground Segment			
Materials and Processes			
Structures			
Electronic Components			
Software			
Basic Research for Space Technology			
Small Satellite Activities			

SwissApollo

“Space for Inspiration”

References

- Several lectures for general public, children and students promoting STEM
- Several panel discussions with astronauts and scientists promoting STEM
- Official partner of the Swiss Transport Museum and Sciencecity for space exhibits
- Proofreading of the publication “Science & Fiction”, Professor Johannes Geiss, Berner Universitätsschriften
- Recommendation of the book “Innovation, the NASA way”, Rod Pyle, USA
- Television commercial starring astronaut Buzz Aldrin for Swiss Tourism

Profile

SWISSAPOLLO is a company dedicated to inspire people, by perpetuating the memory of Switzerland’s contribution to the Apollo Lunar program and keep the links and friendship with its actors.

We promote Science, Technology, Engineering and Mathematics (STEM) to the general public, especially children and students.

We support the pursuance of space initiatives, in particular through the inspiring accounts of its historical pioneers.

Field of Expertise

- Motivational speaker in fields of Space and Human Developments
- Organization and chairing conferences and panels discussions
- Awareness and promotion of STEM for children and students
- Appearance of key people involved in space program
- Expertise in space history, especially the Swiss implication during Apollo program
- Archive with books, newspapers and various artifacts related to Apollo.



SWISSAPOLLO LLC
Landenbergstrasse 7
CH – 8004 Winterthur
Tel: +41 (0) 78 800 8175
info@swissapollo.com
www.swissapollo.com

Segment	Research	Development	Production
Earth Observation		✓	
Life and Physical Sciences			
Satellite-based Applications			
Instruments and Payloads		✓	
Spacecraft and on-board Equipment		✓	
Ground Segment			✓
Materials and Processes			✓
Structures		✓	
Electronic Components		✓	
Software			
Basic Research for Space Technology	✓		
Small Satellite Activities	✓	✓	

SWISSto12 SA

“3D printed antennas, waveguides and filters”

Profile

SWISSto12 is a start-up company that spun off from the Swiss Federal Institute of Technology in Lausanne (EPFL), in 2011. The company pioneers in the field of radio frequency antenna, waveguide and filter products based on additive manufacturing. Specialized product designs are 3D printed in high-performance polymers or metals and subsequently metal plated through proprietary processes. This novel approach to manufacturing features drastic weight reductions, extended design flexibility and reduced costs. SWISSto12 products are commercialized for use both on ground and in space for satellite telecommunication applications.

Field of Expertise

- RF antennas, waveguides and filters
- Satellite RF payload components
- Satellite user terminal RF components
- Additive manufacturing of polymers and metals for RF applications
- Surface treatment of additive manufactured products
- RF and mechanical design and testing of RF components

References

- SWISSto12 is a highly innovative technology company, which has already successfully tested its products with key industrial customers in the satellite telecommunications industry such as:
- The European Space Agency
 - Cobham antenna systems
 - Thales Alenia Space
 - Airbus Defense and Space

The company is currently in the process of completing the qualification of its products for aerospace and space applications in view of first flights in 2018. In parallel, its products are already commercialized for use on the ground and for scientific research applications.



SWISSto12 SA
EPFL Innovation Park, Building L
Chemin de la Dent d'Oche 1B
CH - 1024 Ecublens
Tel: +41 (0) 21 353 02 40
info@swissto12.ch
www.swissto12.ch

Segment	Research	Development	Production
Earth Observation			
Life and Physical Sciences			
Satellite-based Applications	✓	✓	✓
Instruments and Payloads	✓	✓	✓
Spacecraft and on-board Equipment	✓	✓	✓
Ground Segment	✓	✓	✓
Materials and Processes		✓	✓
Structures			
Electronic Components	✓	✓	✓
Software		✓	✓
Basic Research for Space Technology	✓		
Small Satellite Activities			

Synopta GmbH

“Opto-electronic systems for space and terrestrial use”

References

Synopta is involved in or responsible for following OGS types:

- ESA Optical Ground Station (OGS)
- Mobile Tesat OGS
- Transportable Adaptive Optical Ground Station (T-AOGS)

Synopta delivers CPA 135 for Tesat LCTs used in Copernicus/ EDRS, flying on the following missions:

- Sentinel 1A
- EDRS-A
- Sentinel 1B
- EDRS-C
- Sentinel 2B
- MAIT on-going, e.g. for Sentinel 1+2, C+D

Profile

Synopta GmbH was founded in Eggersriet (SG), Switzerland, in early 2004. The purpose of its business is consulting in strategic and technical areas, the representation of companies in the European market, as well as development, production, distribution of opto-electronic devices and other high-quality goods.

In addition to consulting and service activities, Synopta also develops and produces complex opto-electronic systems for space and terrestrial use, both as serial products with small or medium-sized numbers, as well as individual productions/ prototypes.

The owner of Synopta GmbH is Dr. Reinhard H. Czichy.

Field of Expertise

The competences of Synopta include

- Consulting in business development and strategic planning
- Public Affairs Management
- Risk and Project management
- Development skills in the fields of: Systems Engineering, Orbit analysis, Atmospheric channel modeling, Optics, Opto-Electronics, Adaptive Optics, Mechanisms, Control Electronics, Communication electronics, Software
- Beam steering and -stabilizing systems
- Optical Ground Stations
- Communication Systems
- Test systems for optical and optoelectronic devices
- Design, development and production of devices for space applications

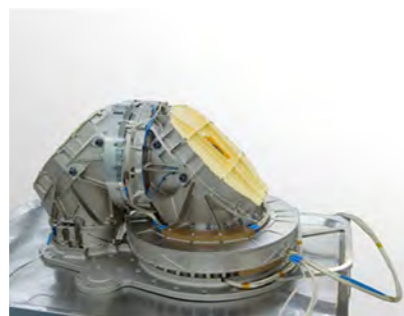

Synopta GmbH

Postfach 53, Wiesenstrasse 6
CH - 9034 Eggersriet
Tel: +41 (0) 71 877 29 36
info@synopta.ch
www.synopta.ch

Segment	Research	Development	Production
Earth Observation	✓	✓	✓
Life and Physical Sciences		✓	
Satellite-based Applications			
Instruments and Payloads	✓	✓	✓
Spacecraft and on-board Equipment	✓	✓	✓
Ground Segment			
Materials and Processes			
Structures			
Electronic Components			
Software			
Basic Research for Space Technology		✓	
Small Satellite Activities			

Thales Alenia Space Schweiz AG

“Space for Life”

Profile

Thales Alenia Space in Switzerland entered the field of Optics and Electronics Systems more than 20 years ago. During this time our engineers gained substantial know-how that resulted in the design and manufacturing of sophisticated optics and electronics systems for space applications. In parallel, the needed infrastructure in the sense of clean rooms and measurement equipment was implemented to support the activities. Thales Alenia Space in Switzerland has demonstrated its high level of competence in several projects involving engineering, testing and production of optics and electronics.

Field of Expertise

Thales Alenia Space in Switzerland has demonstrated its high level of competence in several projects involving engineering, testing and production of optics and electronics, such as:

- Cameras for Planetary Research
- Front End Electronics for various sensors, including CCD readout
- Radiation Monitors
- Optical Terminals for broadband inter-satellite and space-to-ground communications
- Highly stable optical structures
- Optical Harnesses for satellites
- Laser Altimeters for planetary research

References

- BepiColombo - Receiver Subsystem for BELA Instrument
- Sentinel-5p - Detector Module for TROPOMI Instrument
- Exomars Trace Gas Orbiter - Telescope for CaSSIS Instrument
- LISA Pathfinder - Laser Modulator, Delta-CCU Electronics and Inertial - Sensor Front End Electronics
- Alphasat, Sentinel-1/2 A/B - Telescope for Laser Communication Terminal
- SMOS - Optical Harness for MIRA

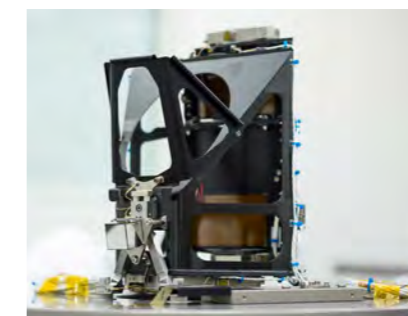
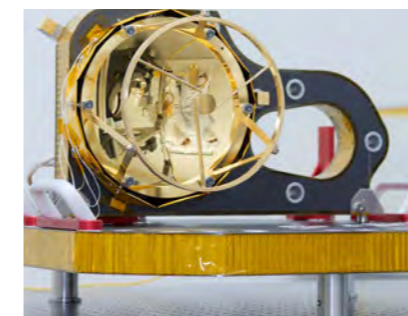

Thales Alenia Space Schweiz AG

Schaffhauserstrasse 580
CH - 8052 Zurich
Tel: +41 (0) 44 99 70 00
www.thalesaleniaspace.com/switzerland

Segment	Research	Development	Production
Earth Observation			
Life and Physical Sciences			
Satellite-based Applications			
Instruments and Payloads	✓	✓	✓
Spacecraft and on-board Equipment			
Ground Segment			
Materials and Processes	✓	✓	✓
Structures			
Electronic Components			
Software			
Basic Research for Space Technology			
Small Satellite Activities			

TSS InnovationsProjekte GmbH

“Flexibility is our own DNA”

References

- High Temperature Shape Memory Alloys based HDRM
- Shape memory alloys for damping
- Shape Memory mechanism for latch and release of satellite and aerospace modules and payload (SHREK)

Profile

TSS InnovationsProjekte GmbH has been established in 2011 as the Swiss spin-off of one of the main Italian spring manufacturer (Technosprings Italia srl), inheriting its know-how and technical expertise. This includes also a fifteen-years experience in the field of shape memory alloys. TSS designs and produces high quality metallic springs and bent components for any application, in particular aerospace, automotive, medical and watchmaking. TSS is active also in innovative research projects in the aerospace and medical fields. The company quality system is certified ISO 9001:2008, EN 9100:2009 and ISO 13485:2003.

Field of Expertise

- Design and manufacturing of high quality springs and bent components from Ø0.06mm in any metallic material, e.g. steel, Titanium, Inconel, Nivaflex, Pt-Ir, Copper, Bronze
- Design and manufacturing of actuators and devices based on shape memory alloy
- SHREK: Shape Memory mechanism for latch and release of satellite and aerospace modules and payload (Technosprings Italia srl in collaboration with SELEX ES, AEREA SpA, CNR-IENI)



TSS Innovations Projekte GmbH

TSS InnovationsProjekte GmbH

Via Cantonale / Resiga de Scima
Stabile «In Cava»
CH - 6535 Roveredo
tss.en@tss-innovationsprojekte.ch
http://tss-innovationsprojekte.ch

Segment	Research	Development	Production
Earth Observation	✓		
Life and Physical Sciences			
Satellite-based Applications	✓	✓	✓
Instruments and Payloads	✓	✓	✓
Spacecraft and on-board Equipment			
Ground Segment	✓	✓	✓
Materials and Processes			
Structures			
Electronic Components	✓	✓	✓
Software	✓	✓	✓
Basic Research for Space Technology	✓		
Small Satellite Activities			

ViaSat Antenna Systems SA

“Truly Global, Truly Broadband”

Profile

ViaSat is on a mission to connect the world. A global broadband services and technology company, ViaSat designs, integrates and delivers secure, high-performance satellite and wireless services. Its business unit in Lausanne is a centre of excellence for phased arrays and new technologies, products and applications for satellite communications. Applications for satellite communication include drone systems, connected vehicles, 3D printing and IoT. It is also a service and operations centre for Europe, developing key elements of the satellite system for ViaSat's next generation of high capacity satellites.

Field of Expertise

- Satcom systems for high-capacity satellites
- Design, manufacture and test antennas for mobile satellite telecommunication
- Centre of excellence for phased array
- Drones systems and applications
- Connected vehicles
- Internet of Things
- 3D Printing

References

- Project AIDAN - Public Private Partnership with European Space Agency (ESA) to develop, validate and roll out a highly innovative ground segment for third generation class satellite system ViaSat-3.
- SatCare - ESA project of in-ambulance telemedicine with broadband satellite connectivity.
- ViaDrone - ESA project to fly Remotely Piloted Aircraft Systems in civilian airspace for new applications.



Viasat

ViaSat Antenna Systems SA

EPFL - Quartier de l'Innovation, Building J
Route J.Colladon, CH - 1015 Lausanne
Tel:+41 (0) 21 691 40 62
jast@viasat.com
www.viasat.com

RESEARCH

Segment	Research	Development	Production
Earth Observation			
Life and Physical Sciences	✓	✓	✓
Satellite-based Applications			
Instruments and Payloads	✓	✓	✓
Spacecraft and on-board Equipment	✓		
Ground Segment	✓		
Materials and Processes	✓	✓	
Structures	✓		
Electronic Components	✓	✓	✓
Software	✓	✓	✓
Basic Research for Space Technology	✓		
Small Satellite Activities	✓	✓	

CERN

Space Activities

- Support of scientific space missions, including on ISS, mainly in astroparticle physics, and in astronomy, and cosmology (e.g., Euclid, AMS). Instrument performance characterisation and calibration.
- Testing facilities: ground testing and qualification of flight equipment, mainly for irradiation (e.g., CHARM, VESPER, IRRAD), and for materials characterisation, cryogenics and magnetic testing.
- Technologies: from microelectronics to data handling, from radiation monitoring to cryogenics and from thermal management to superconducting magnets.

Profile

Physicists and engineers at the European Organization for Nuclear Research use the world's largest and most complex scientific instruments to study the basic constituents of matter – fundamental particles. The particles are made to collide at close to the speed of light. The process gives physicists clues about how the particles interact, and provides insights into the fundamental laws of nature. CERN's mission is: to provide a unique range of particle accelerators that enable research at the forefront of human knowledge, to perform world-class research in fundamental physics, to unite people from all over the world, and to push the frontiers of science and technology, for the benefit of all.

CERN at a Glance

- World-class research in particle physics
- Expertise in the fields of accelerators, detectors, and computing
- 2560 members employed by CERN, but up to 13 000 people on site at any one time
- 22 Member States
- 2016 Budget: 1153.2 MCHF
- Currently 18 start-ups using CERN technology
- Main application fields beyond particle physics: medical technologies and aerospace applications
- CERN's dedicated Knowledge Transfer group engages with experts in science, technology and industry to create opportunities for the transfer of CERN's technology and know-how.



CERN
 Knowledge Transfer Group – Aerospace Applications
 CH - 1211 Geneva 23
 Tel: +41 (0) 22 767 97 02
 enrico.chesta@cern.ch
<http://kt.cern/aerospace>

Segment	Research	Development	Production
Earth Observation	✓		
Life and Physical Sciences	✓	✓	
Satellite-based Applications			
Instruments and Payloads	✓	✓	
Spacecraft and on-board Equipment	✓		
Ground Segment			
Materials and Processes	✓		
Structures			
Electronic Components	✓		
Software			
Basic Research for Space Technology	✓		
Small Satellite Activities	✓	✓	

CSEM

Profile

CSEM is a private, non-profit research and technology organization and a Swiss innovation accelerator—a catalyst for the transfer of technologies and know-how from fundamental research to industry. CSEM delivers unique advanced technologies to the industrial sector, thereby reinforcing the sector's competitive advantage. Supported by federal and cantonal authorities CSEM bridges the gap between academic findings and industrial requirements. CSEM's research strategy is built around five strategic programmes: microsystems technology, systems engineering, ultra-low power integrated systems, surface engineering and photovoltaics and energy management.

CSEM at a Glance

- (in 2015)
- Headquartered in Neuchâtel, with 4 regional centres in Zurich, Muttensz, Alpnach, and Landquart.
 - Total Income: 83 MCHF
 - Income in Space: 5.4 MCHF
 - 450 employees
 - 47 nationalities
 - Over 15 years, 42 new ventures (start-ups & spin-offs)
 - 186 overall patent families

Space Activities

- High precision mechanisms and scientific instrumentation
- Atomic clocks
- Flash imaging LiDAR
- Robotics, control engineering, firmware
- Micro-sensors, MEMS and MOEMS (from design to small volume production and reliability)
- Biomedical engineering (integrated sensors, telemedicine)
- Life support and habitation systems at the ISS
- Telecommunication (intra-satellite wireless communication, antenna miniaturisation, etc.)

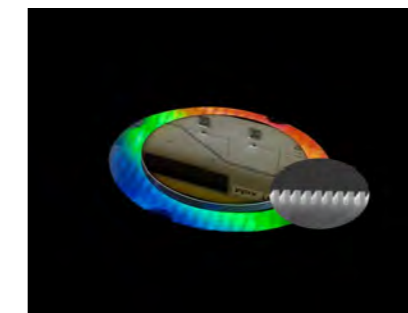

CSEM
 Rue Jaquet-Droz 1
 CH - 2002 Neuchâtel
 Tel: +41 (0) 32 720 51 11
 info@csem.ch
www.csem.ch

Segment	Research	Development	Production
Earth Observation	✓	✓	
Life and Physical Sciences	✓	✓	
Satellite-based Applications	✓	✓	
Instruments and Payloads			
Spacecraft and on-board Equipment			
Ground Segment			
Materials and Processes			
Structures			
Electronic Components			
Software			
Basic Research for Space Technology			
Small Satellite Activities			

EAWAG

Space Activities

- Surface water quality remote sensing
- Optical properties of natural waters
- Remote sensing of plant-water interactions
- Urban flood monitoring
- Model assimilation of Earth observation products

Profile

The Swiss Federal Institute of Aquatic Science and Technology, Eawag, is one of the world's leading water research institutes. It combines natural sciences, engineering and social sciences, which enables comprehensive research of water from pristine rivers and lakes, right through to automated waste water management systems. In close collaboration with authorities and other interest groups, Eawag provides a unique research environment to investigate questions that lead to new scientific findings and to solutions for the basic challenges facing society. Spaceborne Earth observation is an essential information source for both, and fiducial reference measurements acquired at Eawag aim to further improve their use on local to global scales.

EAWAG at a Glance

- Operating income: 82.6 MCHF
- 500 staff members
- 13 major awards (in 2017)
- 8 spin-offs
- 103 SNF/NCCR/Innosuisse and 31 EU projects on-going

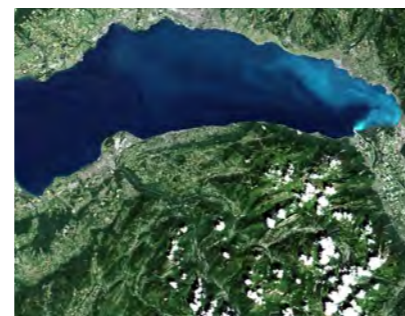

eawag
aquatic research 000

Swiss Federal Institute of
Aquatic Science and Technology
Ueberlandstrasse 133
CH - 8600 Dübendorf
Tel: +41 (0) 58 765 55 11
info@eawag.ch
www.eawag.ch

Segment	Research	Development	Production
Earth Observation	✓	✓	
Life and Physical Sciences	✓	✓	
Satellite-based Applications			
Instruments and Payloads	✓	✓	
Spacecraft and on-board Equipment			
Ground Segment			
Materials and Processes	✓	✓	
Structures			
Electronic Components			
Software	✓	✓	
Basic Research for Space Technology	✓	✓	
Small Satellite Activities			

Empa

Profile

Empa, the Swiss Federal Laboratories for Materials Science and Technology, an interdisciplinary research institute of the ETH Domain, conducts cutting-edge materials and technology research. Our research and development activities focus on meeting the requirements of industry and the needs of society, and thus link applications-oriented research to the practical implementation of new ideas in the areas of nanostructured, "smart" materials and surfaces, environmental, energy and sustainable building technologies as well as bio-technology and medical technology.

Empa at a Glance

- Operating Income: 192.5 MCHF
- 966 staff members
- 65 prizes and awards (in 2017)
- 72 spin-offs and start-ups
- 120 SNSF, 103 CTI/Innosuisse and 69 EU currently undergoing projects

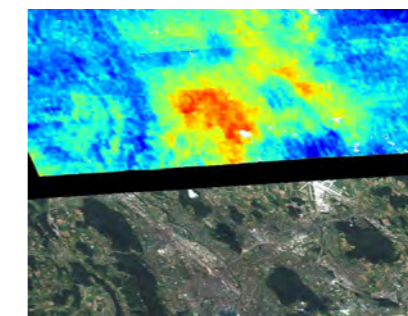

Space Activities

- Air pollution and climate change: remote sensing and modeling
- Energy: flexible high efficiency solar cells
- Safety: body monitoring with smart sensing textiles
- Reliability: electronic systems
- Materials and processes: additive manufacturing & X-ray analytics

Empa
Materials Science and Technology

EMPA

Ueberlandstrasse 129
CH - 8600 Dübendorf
Tel: +41 (0) 58 765 11 11
antonia.neels@empa.ch
www.empa.ch

Segment	Research	Development	Production
Earth Observation	✓	✓	✓
Life and Physical Sciences			
Satellite-based Applications			
Instruments and Payloads	✓	✓	✓
Spacecraft and on-board Equipment			
Ground Segment			
Materials and Processes	✓	✓	
Structures			
Electronic Components			
Software	✓		
Basic Research for Space Technology	✓		
Small Satellite Activities	✓		

PMOD/WRC

Space Activities

- Mechanical Workshop
- Electronic Workshop
- Cleanroom Iso7
- Cleanbench Iso5
- Vacuum Chamber
- Optical Laboratory

Profile

The Physikalisch-Meteorologisches Observatorium and World Radiation Center is a private non-commercial organization, which is a branch of the SFI foundation in Davos.

The PMOD/WRC

- Serves as an international center for the calibration of meteorological instruments measuring radiation;
- Develops radiometers for ground based and space based use;
- Researches the influence of radiation on the terrestrial climate

Measurements obtained in space and on the ground are used for research projects, which assess the relation of the solar variations to climate change and space weather.

PMOD/WRC at a Glance

- Annual budget: 5.8 M CHF
- 40+ staff members
- Operational service of four calibration centers for the World Meteorological Organization:
 - Solar Radiometry Section (WRC-SRS)
 - Infrared Radiometry (WRC-IRS)
 - Atmospheric turbidity (WRC-WORCC)
 - UV radiometry (WRC-WCC-UV)
- Research: Radiation metrology, Solar physics, solar influence on climate, atmosphere, and Space Weather
- Collaborations nationally with ETH Zürich, University of Zürich, University of Bern, and Oeschger center



PMOD/WRC
 Dorfstrasse 33
 CH - 7260 Davos Dorf
 Tel: +41 (0) 58 467 51 00
 www.pmodwrc.ch



ACADEMIA

Segment	Research	Development	Production
Earth Observation	✓		
Life and Physical Sciences	✓		
Satellite-based Applications	✓	✓	
Instruments and Payloads	✓		✓
Spacecraft and on-board Equipment	✓	✓	✓
Ground Segment	✓	✓	
Materials and Processes	✓	✓	✓
Structures	✓		
Electronic Components	✓	✓	✓
Software	✓	✓	✓
Basic Research for Space Technology	✓		
Small Satellite Activities	✓	✓	✓

EPFL

Profile

The École Polytechnique Fédérale de Lausanne (EPFL) is Europe's most cosmopolitan technical university with students, professors and staff from over 110 nations. A dynamic environment, open to Switzerland and the world, EPFL is centered on its three missions: teaching, research and technology transfer. EPFL works together with an extensive network of partners including other universities and institutes of technology, developing and emerging countries, secondary schools and colleges, industry and economy, political circles and the general public, to bring about real impact for society.

EPFL at a Glance

- Created in 1968 (roots back to 1853)
- 10'124 students (BSc, MSc, PhD)
- 338 faculties
- Annual Expenses: 965 MCHF
- 210 start-ups established between 2000 and 2015
- 14th World University for Engineering and Technology (2015 THE)



ÉCOLE POLYTECHNIQUE
FÉDÉRALE DE LAUSANNE

EPFL

École Polytechnique Fédérale de Lausanne
Route Cantonale
CH - 1015 Lausanne
<http://epfl.ch>
info@epfl.ch

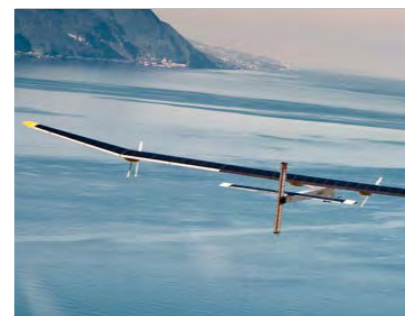

Applied Computing and Mechanics Laboratory (IMAC)

Profile

The mission of IMAC is to take advantage of multi-disciplinary synergies in order to study the real behavior large civil-engineering structures. We maintain competence in structural mechanics, dynamics, measurement of full-scale structures, optics, material science and information technology.

Space competences

- Active and intelligent structures
- Infrastructure monitoring, diagnosis and prediction

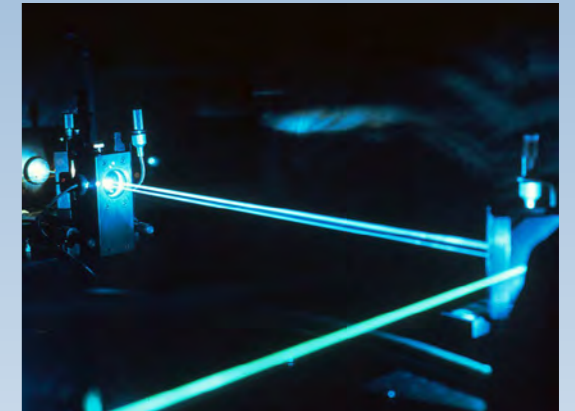

Contact

EPFL-ENAC-IIC-IMAC GC G1 537 • Station 18 • CH - 1015 Lausanne •
Tel: +41 (0) 21 693 80 15 • <http://imac.epfl.ch>



ÉCOLE POLYTECHNIQUE
FÉDÉRALE DE LAUSANNE

Biorobotics Laboratory (BIOROB)

Profile

The BioRob works on the computational aspects of movement control, sensorimotor coordination, and learning in animals and in robots. We are interested in using robots and numerical simulation to study the neural mechanisms underlying movement control and learning in animals, and in return to take inspiration from animals to design new control methods for robotics.

Space competences

- Self-reconfigurable modular robots
Roombots
- Lola-OP snake robot
- Pleurobot
- Salamandra robotica II
- Cheetah-Cub a compliant quadruped robot



Contact

EPFL STI IBI BIOROB • ME D1 1226 • Station 9 • CH - 1015 Lausanne •
Tel: +41 (0) 21 693 26 58 • auke.ijspeert@epfl.ch • <http://biorob.epfl.ch>

BIOROB
Laboratoire de biorobotique

Composite Construction Laboratory (CCLAB)

Profile

The research mission of the Composite Construction Laboratory is to make significant contributions to the development of a new generation of innovative high-performance structural systems. Research interests are focused on composite or hybrid materials and engineering structures with an emphasis on lightweight structures and advanced composite materials.

Space competences

CCLab performs high level research dealing with specific highly innovative topics in the field of fatigue and damage progression during fatigue loading of engineering structures.



Contact

EPFL-ENAC-CCLAB • BP 2225 • Station 16 • CH - 1015 Lausanne •

Tel: +41 (0) 21 693 32 52 • secretariat.cclab@epfl.ch • <http://cclab.epfl.ch>



Computational Mathematics and Simulation Science (MCSS)

Profile

The MCSS focuses on the development, analysis and application of accurate computational methods for time-dependent differential equations. This includes research activities in discontinuous Galerkin and spectral methods, certified reduced basis methods, methods of uncertainty quantification, methods for multiscale problems in time and space, and fractional differential equations.

Space competences

- Methods for multiscale problems in time and space
- Computational techniques for black hole dynamics
- Methods for detection of radiated space-time waveforms

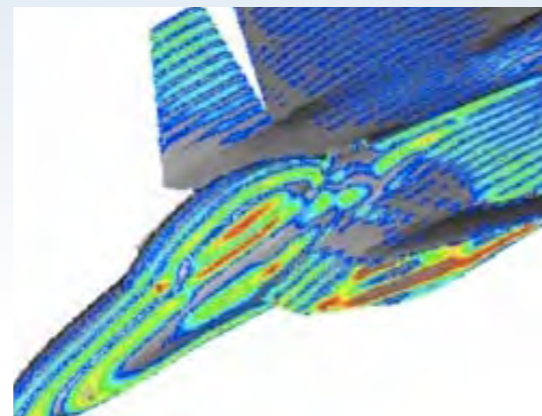

Contact

EPFL-SB-MATHICSE-MCSS • MCSS MA C2 652 • Station 8 • CH - 1015 Lausanne •

Tel: +41 (0) 21 69 3 03 51 • jan.hesthaven@epfl.ch • <http://mcss.epfl.ch>



Earth and Planetary Science Laboratory (EPSL)

Profile

The EPSL aims at understanding how planetary bodies formed and evolved through the study of processes happening on surfaces, in mantles and in cores. Scientists in the group use various techniques of physics and chemistry to characterize the composition and behavior of planetary materials with application to planets (the Earth, Mars), moons (the Moon, icy satellites), and smaller objects (asteroids and meteorites).

Space competences

- Science Lead in the phase 0 of the SOLVE mission
- Remote sensing of planetary surfaces
- Study of meteorite samples
- Earth observation from space

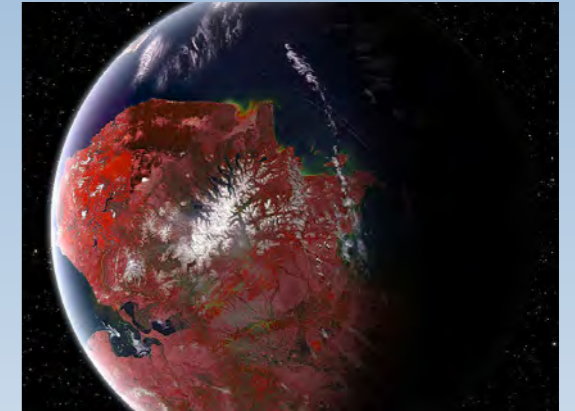

Contact

EPFL SB ICMP EPSL • PH D2 435 • Station 3 • CH - 1015 Lausanne •

Tel: +41 (0) 21 693 33 75 • caroline.pletscher@epfl.ch • <http://epsl.epfl.ch>



Embedded Systems Laboratory (ESL)

Profile

The Embedded Systems Laboratory (ESL) focuses on the definition of system-level multi-objective design methods, optimization methodologies and tools for high-performance embedded systems and nano-scale Multi-Processor System-on-Chip (MPSoC) architectures.

Space competences

- 3D Stacked Architectures with Interlayer Cooling
- Programming for Future 3D Architectures with Many Cores
- Dynamically Adaptive Architectures for Nomadic Embedded Systems
- Wearable ICT for Zero Power medical Application

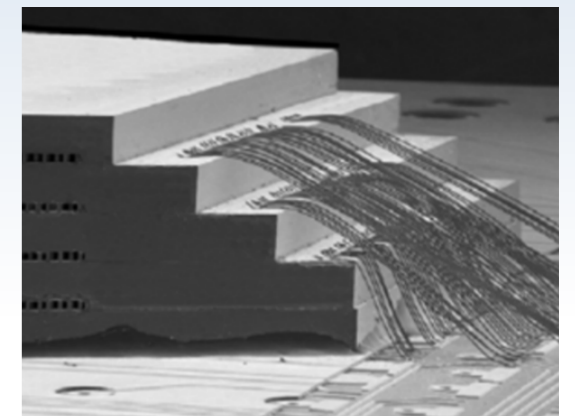

Contact

EPFL-ST-HEL-ESL • ELG 130 (Building ELG) • Station 11 • CH - 1015 Lausanne •

Tel: +41 (0) 21 693 11 32 • <http://esl.epfl.ch>



eSpace

Profile

With the creation of the Space Engineering Center (eSpace) in 2014, EPFL positioned itself as a key player in space technology. As part of its mission, eSpace is actively training a new generation of space engineers, ready to respond to the upcoming rise in small satellite constellations. eSpace is at the forefront of spacecraft development, pushing the capabilities of small satellites beyond anything achieved until now.

Space competences

- Earth and space observation
- Electronics
- Materials and structures
- Microtechnology and optics
- Modeling and aerothermodynamics
- Plasma and energy science
- Robotics and mechanical systems
- Software



Contact

Space Engineering Center EPFL • Station 13 • CH - 1015 Lausanne • Tel:+41 (0) 21 693 69 67 • espace@epfl.ch • <http://eSpace.epfl.ch>



Geodetic Engineering Laboratory (TOPO)

Profile

Position and attitude determination of moving platforms or subjects is the mainstream of the lab research activity. The expertise in algorithm development for real-time or post-mission positioning is applied to precise trajectory determination of land or airborne vehicles and pedestrians. TOPO makes use of satellite based (GPS, Glonass, Galileo) positioning, inertial sensors, magnetic sensors, imagery and networked based positioning.

Space competences

- Geodesy, surveying and cartography
- Development of algorithms in the field of geodesy
- Integration and calibration of sensors
- Development in the field of satellite positioning

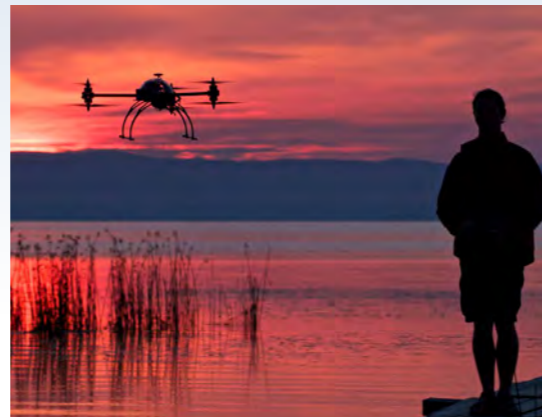

Contact

EPFL ENAC TOPO • Bâtiment GC • Station 18 • CH - 1015 Lausanne • Tel:+41 (0) 21 693 27 55 • secretariat.topo@epfl.ch • <http://topo.epfl.ch>



Group for Fibre Optics (GFO)

Profile

The core research of the group is oriented towards advanced applications of optical fibres that range from optical signal processing to sophisticated sensing techniques. The group is also a key player in distributed fibre sensing based on optical nonlinearities. This type of sensors is foreseen to be an essential tool to secure critical installations, such as dams, tunnels and pipelines.

Space competences

- Optical fibres for advanced applications
- Optical signal processing
- Optical sensing
- Distributed fibre sensing
- Microwave photonics
- Several ESA funding for PhD, advanced research and industrial applications

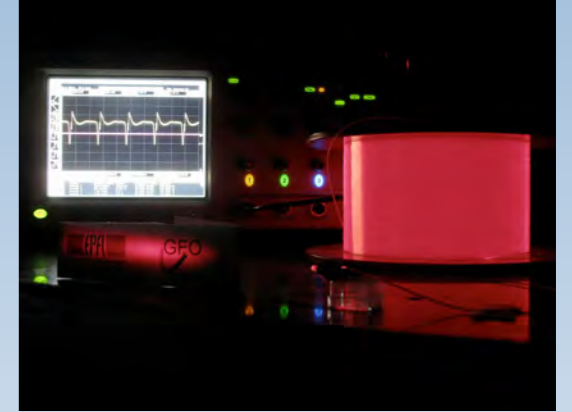

Contact

EPFL-STI-GR-SCI-LT • Station 11 • CH - 1015 Lausanne • Tel:+41 (0) 21 693 47 74 • luc.thevenaz@epfl.ch • <http://gfo.epfl.ch/>



Laboratory for Applied Mechanical Design (LAMD)

Profile

The LAMD focuses on the design and experimental investigation of small scale turbomachinery for decentralized energy conversion. Typical applications range from small scale gas turbines, compressors to high speed expanders for waste heat recovery. The LAMD seeks strong ties with industry as well as with other academic institutions connecting its research with "real world" problems through collaborative projects.

Space competences

- Design and choice of journal bearing technology
- Sealing technology
- Scaling issues on the aerodynamic turbomachinery design
- Integrated design methodologies
- Development of gas-bearing supported turbocompressors for multi-stage, high-temperature lift heat pumps

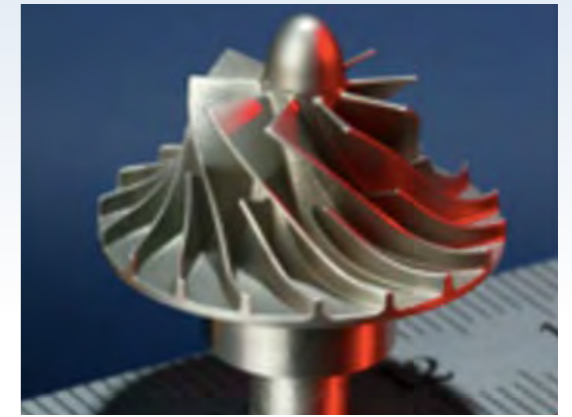

Contact

EPFL IGM LAMD • Maladière 71b • CP 526 • CH - 2002 Neuchâtel 2 • Tel:+41 (0) 21 695 45 13 • julie.lenoblezwahlen@epfl.ch • <http://lamd.epfl.ch>



Laboratory of Astrophysics (LASTRO)

Profile

LASTRO addresses fundamental questions regarding the dark sectors of the Universe as well as the formation and evolution of galaxies. These dark sectors include the study of dark matter and the elusive dark energy responsible for the observed accelerated expansion of the Universe.

Space competences

- Mapping the redshift distribution of galaxies and quasars within the last 11 billion years of the Universe.
- Mapping the distribution of matter within the last 7 billions years of the Universe with imaging surveys
- Probing the first galaxies, which ended the dark ages.



Contact

Laboratoire d'astrophysique EPFL • Observatoire de Sauverny • CH - 1290 Versoix •
Tel: +41 (0) 22 379 24 22 • lastro@epfl.ch • <http://lastro.epfl.ch>



Laboratory of Mechanical Metallurgy (LMM)

Profile

Research at the Laboratory for Mechanical Metallurgy addresses the science and engineering of structural metallic materials, with particular focus on advanced metallic materials. It spans the spectrum from materials processing to the exploration of links between the microstructure and the mechanical or physical properties of metallic materials, generally but not only destined for structural applications.

Space competences

- Microcasting
- Solid Freeform Manufacturing
- Metal matrix composites for thermal management applications
- Deformation of high fraction ceramic particle reinforced metals under elevated triaxial stress
- Measurement and physic of electron / phonon interfacial thermal resistance

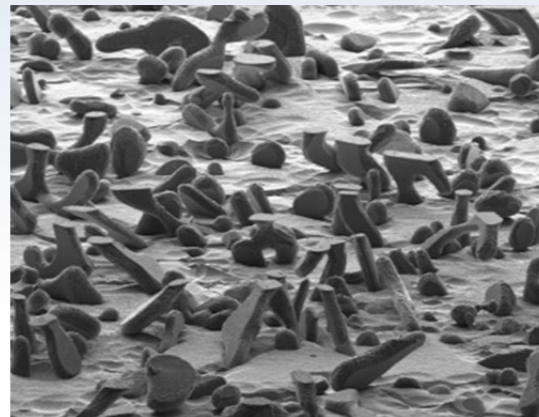

Contact

EPFL-STI-IMX-LMM • MX-D141, Station 12 • CH - 1015 Lausanne • Tel: +41 (0) 21 693 29 15 •
fabienne.ubezio@epfl.ch • <http://lmm.epfl.ch>



Laboratory of Photonics and Quantum Measurements (K-LAB)

Profile

The LPQM has built up major experience in the field of cavity optomechanics and optical frequency comb metrology. The laboratory has been among the first to devote its research to this subject, which by now has become an entire research field in itself. Many of the results published by the laboratory are by now widely cited.

Space competences

- ESA TRP Silicon Nitride Optical Microresonators: space compatibility of SiN microresonators
- ESA-FGU, CSEM Neuchâtel: Micro-Optoelectronic Frequency Generation
- Frequency comb
- Microresonator based frequency combs

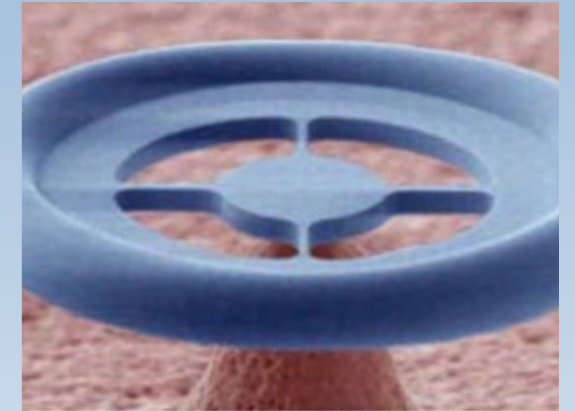

Contact

EPFL-SB-IPHYS-LPQM • Station 3 • CH - 1015 Lausanne • Tel: +41 (0) 21 693 44 28 •
helene.laurens@epfl.ch • <http://k-lab.epfl.ch>



Laboratory of Renewable Energy Science and Engineering (LRESE)

Profile

LRESE aims at developing efficient, economic, sustainable, and robust conversion and storage approaches of renewable energies in fuels, chemical commodities, and power. We specifically focus on the conversion of solar energy into fuels through high temperature solar thermochemical approaches and low temperature photoelectrochemical approaches.

Space competences

- Development of kinetic models for ablation materials
- Coupled experimental-numerical techniques for the morphological and transport characterization in ablation and insulation materials
- Material testing in our high flux solar simulator

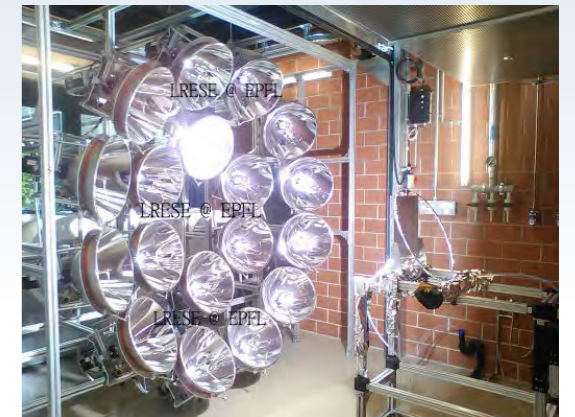

Contact

EPFL-STI-IGM-LRESE • Station 9 • CH - 1015 Lausanne • Tel: +41 (0) 21 693 59 06 •
dominique.espic@epfl.ch • <http://lreese.epfl.ch>



Learning Algorithm and Systems Laboratory (LASA)

Profile

The LASA has a 20 years expertise at developing robust and adaptive control architectures to realize skilful robot motions. Research at LASA combines advanced techniques in control, optimization, machine learning and computer vision for the development of highly reactive robots and to the design of new human-robot interfaces.

Space competences

- Development of algorithms to learn manipulation skills from human demonstration
- Multi-modal processing of tactile, visual and proprioceptive information to control anthropomorphic robotic hands
- Analysis of EMG information for shared control of prostheses



Contact

EPFL-STH-IMT-LASA • Station 9 • CH - 1015 Lausanne • Tel: +41 (0) 21 693 54 64 •
joanna.erfani@epfl.ch • <http://lasa.epfl.ch>



Microsystems for Space Technologies Laboratory (LMTS)

Profile

We develop reliable soft sensors, actuators and transducers for use on Earth as well as in Space. Our research activities cut across different MEMS and miniaturized actuator technologies, with a primary focus on elastomer-based solutions and multi-functional stretchable materials.

Space competences

- Miniaturized polymer actuators and transducers
- Dielectric elastomer actuators
- Modeling and design for silicone-based devices
- Haptic displays for the visually impaired and for sighted users
- Electric micro-propulsion for small spacecraft

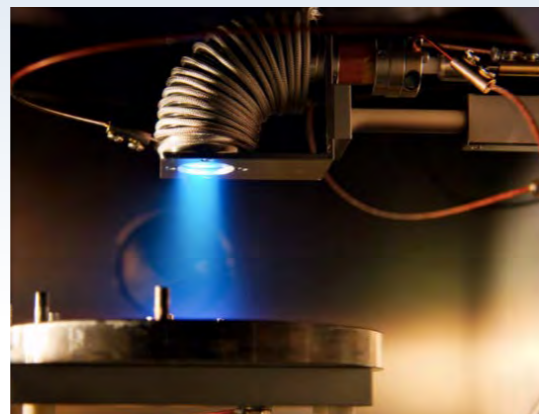

Contact

EPFL-STH-IMT • LMTS Batiment MicroCity • Rue de la Maladière 71b • CP 526 •
CH - 2002 Neuchâtel • Tel: +41 (0) 21 695 44 36 • myriam.poliero@epfl.ch • <http://lmts.epfl.ch>



Physics of Aquatic Systems Laboratory (APHYS)

Profile

The aims of the APHYS are to understand the physical processes in natural waters and the responses of aquatic systems to external forcing. The main focus is on anthropogenic influences, such as nutrients input, hydropower production, use of heat from natural waters, and climate change.

Space competences

- Involvement in the phase 0 of the SOLVE mission
- Inland water remote sensing from hyperspectral imagers
- Coupling information, in situ measurement, modelling



Contact

EPFL-ENAC Station 2 • Bâtiment GR • CH - 1015 Lausanne • Tel: +41 (0) 21 693 63 68 •
secretariat.aphys@epfl.ch • <http://aphys.epfl.ch>



Robotic Systems Laboratory (LSRO)

Profile

Robotic Systems Lab is interested in the design and realization of advanced robotics hardware, mainly in the fields of industrial, ultra-precision and medical robotics. We are specialists in ultra-precision robotics (gravity balance and light trap for Cesium atomic clock built for METAS, the Swiss Office of Standards and Metrology).

Space competences

- Ultra-precision devices based on flexure hinges and parallel kinematics used for telescopes (PRIMA DDL)
- Contact-free magnetic levitation, diamagnetic levitation, very fast rotors (3 mil rpm)
- Electrostatic drives

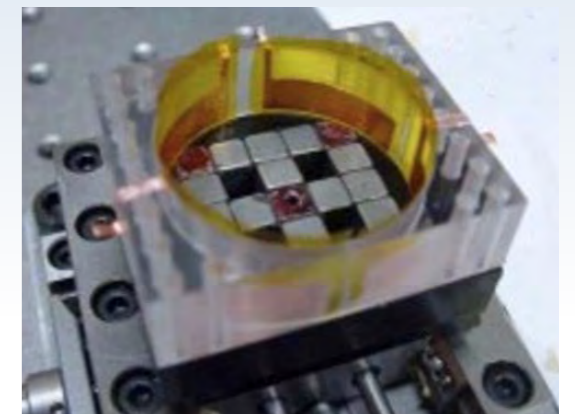

Contact

EPFL-STH-IMT-LSRO • Bat ME, ME D3 1016 • Station 9 • CH - 1015 Lausanne • evelyn.rovero@epfl.ch •
<http://lsro.epfl.ch>



Swiss Plasma Center (SPC)

Profile

The SPC contributes to advancing basic plasma physics of interest for fusion and for space and astrophysical plasmas, as well as for developing industrial plasma applications covering a wide range, from solar cells to packaging industry to aircraft and satellite technology.

Space competences

- Development and basic studies of novel concepts for helicon thrusters for space propulsion
- Experimental and simulation/ numerical studies of satellite slip-ring vacuum breakdown
- Low pressure plasma spraying for high power plasma for thermal testing, surface treatment, and fast coating of surfaces



Contact

EPFL SB CRPP • Station 13 • CH - 1015 Lausanne • Tel:+41 (0) 21 693 34 87 • edith.grueter@epfl.ch • <http://spc.epfl.ch>



Segment	Research	Development	Production
Earth Observation	✓		
Life and Physical Sciences	✓	✓	✓
Satellite-based Applications	✓	✓	
Instruments and Payloads	✓	✓	✓
Spacecraft and on-board Equipment	✓		
Ground Segment			
Materials and Processes	✓		
Structures	✓	✓	
Electronic Components	✓	✓	✓
Software	✓	✓	✓
Basic Research for Space Technology	✓		
Small Satellite Activities	✓	✓	

ETH Zürich

Profile

Freedom and individual responsibility, entrepreneurial spirit and open-mindedness: ETH Zurich stands on a bedrock of true Swiss values. Our university for science and technology dates back to the year 1855, when the founders of modern-day Switzerland created it as a centre of innovation and knowledge. At ETH Zurich, students discover an ideal environment for independent thinking, researchers a climate which inspires top performance. Situated in the heart of Europe, yet forging connections all over the world, ETH Zurich is pioneering effective solutions to the global challenges of today and tomorrow.

ETH Zürich at a Glance

- Created in 1855
- 19'800 students including 4,000 doctoral students, from 120 countries
- 500 professors
- Annual Expenses: 1.8 BCHF
- 355 spin-offs since 1996
- 9th World University (THE 2016)



ETH zürich

ETH ZÜRICH

Rämistrasse 101
CH - 8092 Zürich
Tel:+41 (0) 44 632 11 11
www.ethz.ch

Institute of Agricultural Science (IAS)

Profile

The Institute of Agricultural Sciences (IAS) is the platform for research and teaching in agricultural sciences at ETH Zurich. Today and in the future agricultural research requires a multifaceted approach, integrating agricultural and natural science-based methods and concepts. Agricultural production systems are closely interrelated with other systems and are highly complex.

Space competences

- Sustainable agroecosystems
- Grassland sciences
- Biocommunication and entomology
- Plant nutrition
- Plant biotechnology
- Plant development biology



Contact

ETH Zurich • Inst. for Agricultural Science • Ruth Kühne • LFW C 3 • Universitätstr. 2 • CH - 8092 Zürich • Tel:+41 (0) 44 632 38 35 • lkuehner@ethz.ch • www.ias.ethz.ch

D USYS

Institute for Astronomy

Profile

The Institute for Astronomy, a research Institute within the Department of Physics at ETH, has around 60 staff and students and is organised into five research groups. Our work ranges from observations, using the most powerful telescopes available on the ground as well as in space, to theoretical and numerical calculations. We are also developing new activities in instrumentation by growing our laboratory facilities.

Space competences

- COSMOS partner
- Provider of spectrographs for MUSE (Multi Unit Spectroscopic Explorer)
- Extragalactic astrophysics
- Observational cosmology
- Planet formation
- Black Holes

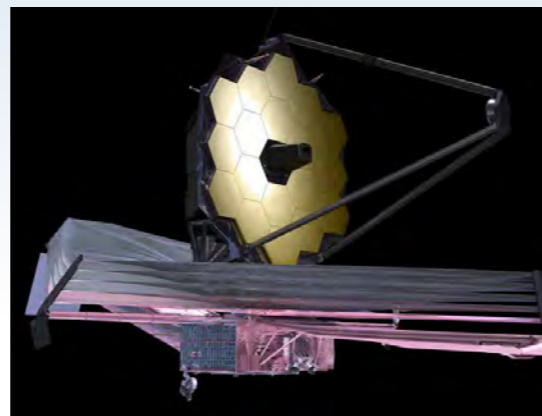

Contact

ETH Zurich • Inst. für Astronomie • HIT J 21.2 • Wolfgang-Pauli-Str. 27 • CH - 8093 Zürich • Tel:+41 (0) 44 633 27 70 • ann.agius@phys.ethz.ch • www.astro.ethz.ch

D PHYS

Institute for Atmospheric and Climate Science (IAC)

Profile

The Institute of Atmosphere and Climate Science (IAC) focuses on atmospheric and climate processes. Research is directed at understanding how human activities alter these processes via changes in greenhouse gases, aerosols, chemical constituents, and land surfaces and how this impacts upon climate, ozone, UV radiation, pollutant exposure, ecosystems, water resources and extreme events.

Space competences

- Atmospheric chemistry
- Atmospheric dynamics
- Atmospheric physics
- Climate and water cycle
- Climate physics
- Land-climate dynamics



Contact

ETH Zurich • Inst. für Atmosphäre und Klima • CHN O 12.3 • Universitätstr. 16 • CH - 8092 Zürich • Tel:+41 (0) 44 633 27 55 • eva.choffat@env.ethz.ch • www.iac.ethz.ch

D USYS

Institute of Design, Materials and Fabrication (IDMF)

Profile

The Institute of Design, Material and Fabrication (IDMF) focuses on Engineering Design as a fundamental discipline within Mechanical Engineering including novel material systems, design methodology, methods and tools, development of innovative technical solutions and novel fabrication processes. IDMF will develop new synergies in research and industrial collaboration as well as in the Engineering Design education at MAVT.

Space competences

- Composite materials
- Adaptive, reconfigurable and active structures
- Product development
- Additive manufacturing
- Design for additive manufacture
- 4D printing
- Computational design methods including design automation, generative design, multi-disciplinary optimization, topology optimization

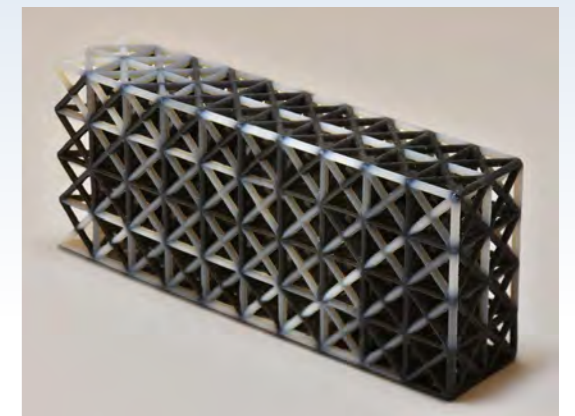

Contact

ETH Zurich • IDMF CLA F35 • Tannenstr. 3 • CH - 8092 Zürich • Tel:+41 (0) 44 632 08 42 • www.idmf.ethz.ch

D MAVT

Institute of Energy Technology (IET)

Profile

The Institute of Energy Technology (IET) is active in research and education in the field of energy science and engineering, aimed at the realization of sustainable energy systems that are environmentally friendly, economically viable, socially compatible, reliable and secure.

Space competences

- Aerothermochemistry and Combustion Systems
- Combustion and Acoustics for Power Systems
- Reliability and Risk Engineering
- Energy Conversion

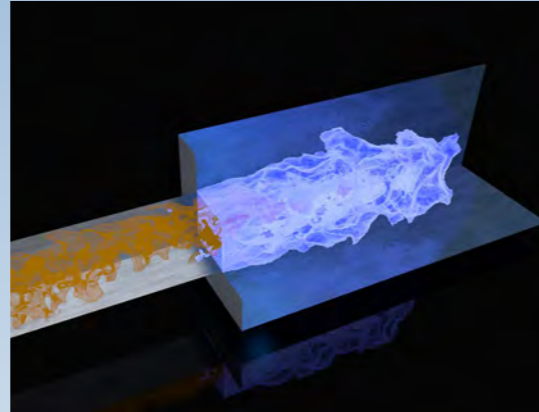

Contact

ETH Zurich • Inst. of Energy Technology • Sonneggstr. 3 • CH - 8092 Zurich • www.iet.ethz.ch



Institute of Environmental Engineering (IfU)

Profile

The Earth Observation Research Group of Institute of Environmental Engineering focuses on remote sensing using innovative techniques and tools for the derivation of quantitative environmental parameters for future satellite missions such as Polarimetric Synthetic Aperture Radar (Pol-SAR), Multi-Parametric SAR Interferometry (Pol-InSAR, TomoSAR), science coordination of ongoing and future SAR missions, and coordination and execution of ground-based and airborne campaign.

Space competences

- Radar Remote Sensing (Synthetic Aperture Radar)
- Environmental Product Development (Hydrosphere, Geosphere, Cryosphere, Biosphere, Urban)
- Electromagnetic Modeling and Inversion
- Image Processing
- Operation of Ground Base Radars (KAPRI)



Contact

ETH Zurich • Prof. I. Hajsek • Earth Observation Research Group • Inst. of Environmental Engineering • HIF D28.1 • Stefano-Francini Platz 5 • CH - 8093 Zurich • hajsek@ifu.baug.ethz.ch • www.eo.ifu.ethz.ch



Institute of Fluid Dynamics (IFD)

Profile

The IFD conducts research in the area of computational and experimental fluid mechanics. Current research includes simulation of turbulent single-phase and multi-phase flows, implementation of modern imaging techniques, simulations of turbulent and unsteady separated flows and the application of probability-densityfunction (PDF) methods to turbulent flows.

Space competences

- Modeling of turbulence and turbulent reactive flows
- Flow in porous Media
- Rarefied gas kinetics
- Flow imaging techniques

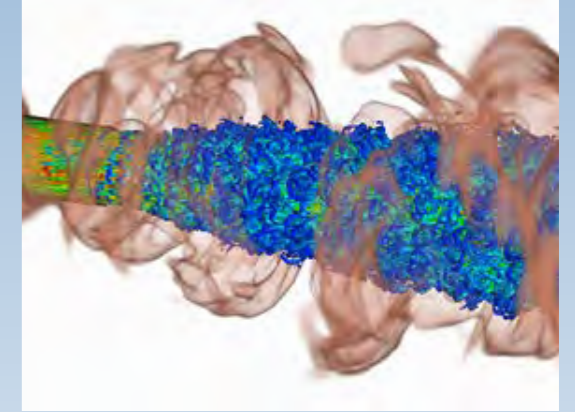

Contact

ETH Zurich • Inst. of Fluid Dynamics • Bianca Maspero • ML H 35 Sonneggstr. 3 • CH - 8092 Zürich • Tel:+41 (0) 44 632 26 47 • maspero@ifd.mavt.ethz.ch • www.ifd.mavt.ethz.ch

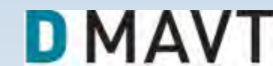

Institute of Geochemistry and Petrology (GeoPetro)

Profile

Research at the Institute of Geochemistry and Petrology combines theoretical, experimental and analytical work on many sample types. Its goal is to better understand the fundamental principles behind the origin of the solar system and the Earth, the formation of continents, mountains and oceans as well as the occurrence of volcanism and ore deposits.

Space competences

- Analyses of extraterrestrial samples returned by space missions or found on Earth (meteorites, dust)
- Cosmochemistry: Detection of elements and their isotopes at high-precision
- Mass spectrometry
- Experimental Petrology
- Volcanology



Contact

ETH Zurich • Inst. of Geochemistry and Petrology • Britt Meyer, Institute Secretary • NW F 82.2 • Clausiusstr. 25 • CH - 8092 Zurich • Tel:+41 (0) 44 632 37 64 • birgitta.meyer@erdw.ethz.ch • www.geopetro.ethz.ch



Institute of Geodesy and Photogrammetry (IGP)

Profile

The Institute of Geodesy and Photogrammetry core competences are the science of geomatics, especially Geodetic Metrology and Engineering Geodesy, Satellite Geodesy Physical Geodesy and Geodynamics, Photogrammetry, Image Analysis and Remote Sensing.

Space competences

- Geodetic metrology
- Satellite geodesy
- Physical geodesy
- Geodynamics
- Photogrammetry
- Image analysis
- Earth observation and remote sensing
- Development of cubesat (CubETH)



Contact

ETH Zurich • Inst. of Geodesy and Photogrammetry • Stefano-Francini-Platz 5 • CH - 8093 Zurich •
Tel: +41 (0) 44 633 30 55 • sek@geod.baug.ethz.ch • www.igp.ethz.ch



Institute of Geophysics

Profile

The Institute of Geophysics delivers leading research and teaching over a wide range of geophysical disciplines, from theoretical modeling towards experimental and observational geophysics. From studying small-scale processes in the shallow subsurface towards large-scale processes forming the Earth and other planets.

Space competences

- Responsible for the measurement and control electronics for the reference gravitation sensor of the LISA Pathfinder space probe
- Involved in the Mars mission "InSight" in the area of seismology and characterization of the shallow Martian subsurface, and the instrument's electronic



Contact

ETH Zurich • Inst. of Geophysics • Sonneggstrasse 5 • CH - 8092 Zürich • Tel: +41 (0) 44 633 26 05 •
johan.robertsson@erdw.ethz.ch • www.geophysics.ethz.ch



Institute for Particle Physics (IPP)

Profile

Construction and operation of (astro-) particle physics experiments:

- at the high-energy frontier (colliders)
- at the low-energy high-intensity frontier
- precision studies of neutrinos
- studies of charged cosmic ray particles (on earth and in space)
- measurements of very high energy cosmic gamma-rays
- Direct and indirect searches for Dark Matter particles

Space competences

- Major contributions to the silicon tracker and control electronics of the AMS-01 detector for Space Shuttle flight STS-91, as well as the AMS-02 detector for the ISS
- Contribution to the operation and data analysis of AMS-01 and AMS-02
- Design, Construction and Operation of the Prototype Synchrotron Radiation Detector for Space Shuttle flight STS-108

Contact

ETH Zurich • Inst. for Particle Physics • Secretariat HPK E32 • Otto-Stern-Weg 5 • CH - 8093 Zürich •
Tel: +41 (0) 44 633 20 31 • ipp-admin@phys.ethz.ch • www.ipp.phys.ethz.ch



Institute of Robotics and Intelligent Systems (IRIS)

Profile

The Inst. of Robotics and Intelligent Systems (IRIS) of ETH Zurich, is doing cutting edge robotics research in a large diversity of fields. It currently consists of eight laboratories that conduct research in areas ranging from nano-robots for biomedicine, to systems for rehabilitation and autonomous aerial vehicles and legged robots.

Space competences

- IRIS offers a large variety in robotics competences of interest for space applications including:
- Solar Airplanes for multi-day operations
 - Visual Navigation Systems
 - Health monitoring and training
 - Compliant Robot Arms
 - Walking and wheeled robots for space applications



Contact

ETH Zurich • Inst. of Robotics and Intelligent Systems • Roland Siegwart • Leonhardstr. 21 • LEE J-205 •
CH - 8092 Zürich • Tel: +41 (0) 44 632 23 58 • rsiegwart@ethz.ch • www.iris.ethz.ch



Institute of Structural Engineering (IBK)

Profile

Institute of Structural Engineering (IBK) competences span steel, timber, concrete, composite and masonry constructions, including fire and seismic hazards. Fundamental research covers structural mechanics, structural health monitoring, risk assessment and uncertainty quantification.

Space competences

- Coupled thermo-mechanical structural testing of spacecraft
- Coupled thermo-mechanical structural modeling and analysis
- Thermo-mechanical hybrid simulation of spacecraft response
- Simulation uncertainty quantification

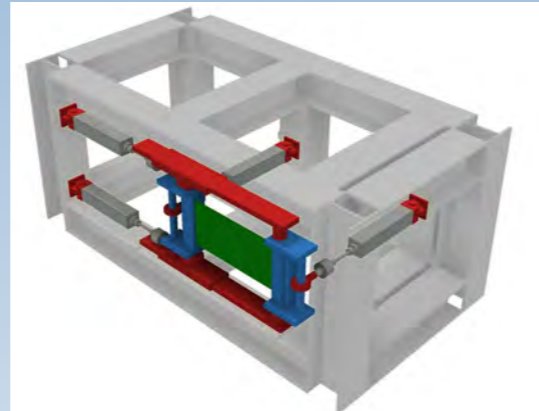

Contact

ETH Zürich • Inst. für Baustatik und Konstruktion • Stefano-Franscini-Platz 5 • CH - 8093 Zürich •
Tel: +41 (0) 44 633 66 69 • neuhaus@ibk.baug.ethz.ch • www.ibk.ethz.ch



Millimeter-Wave Electronics Laboratory (MWE)

Profile

The Millimeter-Wave Electronics group members focus on III-V compound semiconductor devices and processes from modern sub-terahertz applications to all-electronic terahertz sources.

Space competences

- High Electron Mobility Transistors
- Heterojunction Bipolar Transistors

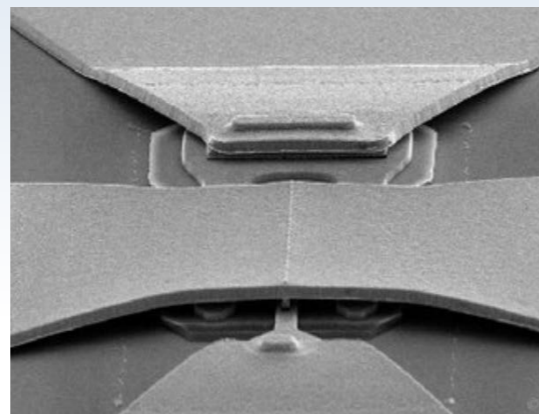

Contact

ETH Zurich D-ITET • MWE - Millimeter-Wave Electronics Group • Gloriastrasse 35 • ETH/ETZ K 82 •
CH - 8092 Zürich • Tel: +41 (0) 44 632 28 10 • bettina.gronau@mwe.ee.ethz.ch

DITET

Segment	Research	Development	Production
Earth Observation	✓	✓	
Life and Physical Sciences		✓	
Satellite-based Applications	✓	✓	
Instruments and Payloads	✓	✓	✓
Spacecraft and on-board Equipment		✓	
Ground Segment	✓	✓	
Materials and Processes	✓	✓	
Structures	✓	✓	✓
Electronic Components	✓	✓	
Software	✓	✓	
Basic Research for Space Technology	✓	✓	
Small Satellite Activities	✓	✓	

FHNW

Profile

The FHNW University of Applied Sciences and Arts Northwestern Switzerland ranks amongst Switzerland's leading and most innovative educational institutions. The campuses are located in the cantons of Aargau, Basel, Basel-Landschaft, and Solothurn, near the borders of Germany and France, and close to the cities of Basel and Zurich. The school of Engineering hosts most of the activities related to space. Its research program involves national and international partners from industry and academy, therefore creating a link between these two poles. The school of Engineering is involved in several European research programs including also space projects. It has experience in hardware and software development.

FHNW at a Glance

- 9 schools
- More than 11,000 students
- 29 bachelor and 18 master programmes
- 58 institutes



n|w University of Applied Sciences and Arts
Northwestern Switzerland

FHNW

Fachhochschule Nordwestschweiz FHNW
Bahnhofstr. 6
CH - 5210 Windisch
Tel: +41 (0) 56 202 77 00
info.technik@fhnw.ch
www.fhnw.ch/technik

Institute of Data Science (I4DS)

Profile

The Institute of Data Science consists of a team of about 60 specialists, including computer scientists, physicists, mathematicians, designers, and communicators. It addresses challenges in a wide variety of projects, exploiting possible synergies across application fields. Space is one of its most prominent domain of activity, for which it develops software as well as hardware for scientific instruments

Space competences

- STIX: X-ray telescope on Solar Orbiter
- X-ray detectors and Grids
- Instrument design
- Testing and calibration
- Ground software
- Date analysis software
- Data mining and analytics
- Project Management

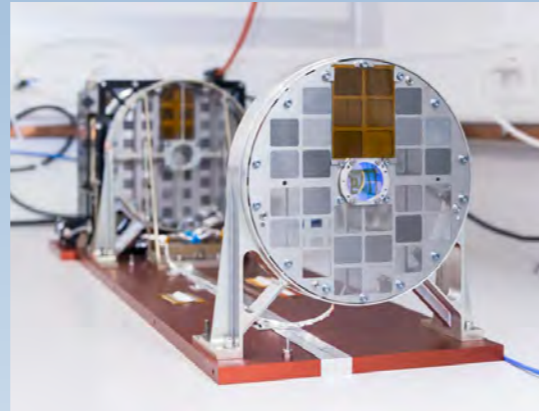

Contact

Prof. André Csillaghy • Institute of Data Science FHNW • Bahnhofstr. 6 • CH - 5210 Windisch •
andre.csillaghy@fhnw.ch



Institute of Geomatics (IGEO)

Profile

Key topics of application-oriented research and development at IGEO are methods and technologies for earth observation, monitoring and satellite-based navigation and measuring, for example using GNSS (Global Navigation Satellite System). Our competences range from the integration of sensors, the development of software and implementation of applications to name but a few. More on <http://www.fhnw.ch/ivgi>

Space competences

- Semi-automatic photogrammetric and spectral processing of multispectral satellite imagery for various applications (e.g. agriculture, archaeology, 3D-modelling)
- Object-based image analysis and change detection by combining spectral and geometric features extracted from satellite imagery
- Development of methods based on GNSS- and IMU-techniques for navigation of unmanned vehicle systems

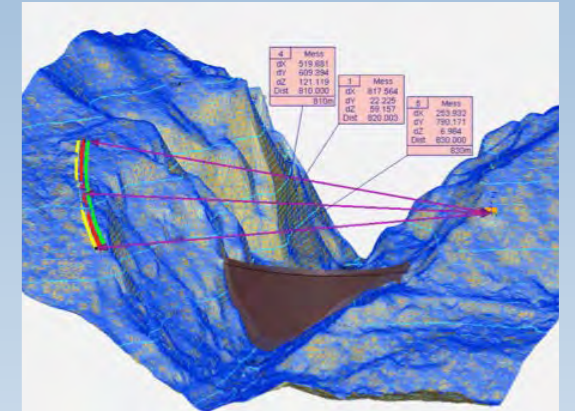

Contact

FHNW Institute of Geomatics (IGEO) • Hofackerstrasse 30 • CH - 4132 Muttenz • Tel: +41(0) 61 228 55 55 •
geomatik.habg@fhnw.ch



Institute of Automation Engineering (IA)

Profile

The IA focuses its application-oriented research and development in the promising systems engineering domain, ranging from the development of smart systems to the integration of sensors and actors to improve functionalities of automated devices & processes. Our main competences include the advancement of automated handling systems, systems analysis & modelling, advanced control systems & signal processing methods, measurement & diagnostic devices, microsystems technology.

Space competences

- Systems integration of measurement & control devices (e.g. with smart sensors & actors)
- Mechatronics test equipment (e.g. for microgravity simulation on earth)
 - Miniaturization of high-rel instruments & sensors (e.g. for cometary ultralow pressure measurement, for outgassing detection on spacecraft and satellite test facilities)
 - Ultrafast FPGA algorithms (e.g. for FFT & filter bank algorithms for radio astronomy, atmosphere physics, general purpose spectral analysis)

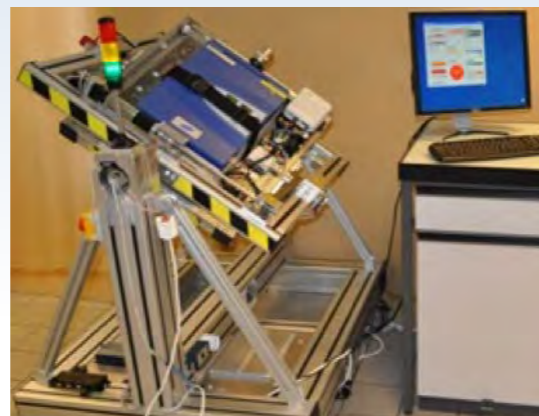

Contact

Prof. Dr. Roland Anderegge • FHNW Institute of Automation Engineering • Klosterzelgstr. 2 •
CH - 5210 Windisch • Tel:+41 (0) 56 202 77 43 • ronald.anderegge@fhnw.ch

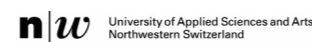

Institute of Polymer Engineering (IKT)

Profile

The IKT is working in the field of polymer science, development of fibre reinforced materials, design of fibre reinforced structures and related manufacturing methods. The institute covers competences all along the value chain for composite materials starting from material development, material characterization, structural design, manufacturing engineering and prototype manufacturing and testing on lab scale.

Space competences

- Systems based on polymers
- Composite structures
- Joining technology for composites
- Landing technologies
- Manufacturing processes



Contact

FHNW Institute of Polymer Engineering • Klosterzelgstr. 2 • CH - 5210 Windisch • Tel:+41 (0) 56 202 74 75 •
info.ikt.technik@fhnw.ch

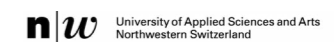

Institute of Product and Production Engineering (IPPE)

Profile

The IPPE is focussed on application-oriented research and development of products and production processes involving cutting-edge technology. The competences include simulation and testing of mechanical systems, additive manufacturing and 3D laser micro-machining. Latest CAE/ CAM systems and modern laboratory infrastructure enable the experimental and numerical expertise required to support our industrial partners.

Space competences

- Lightweight structure design and development
- Material and process development for automation
- Additive manufacturing
- Mechanical testing (static, sine and random vibration, shock, fatigue)

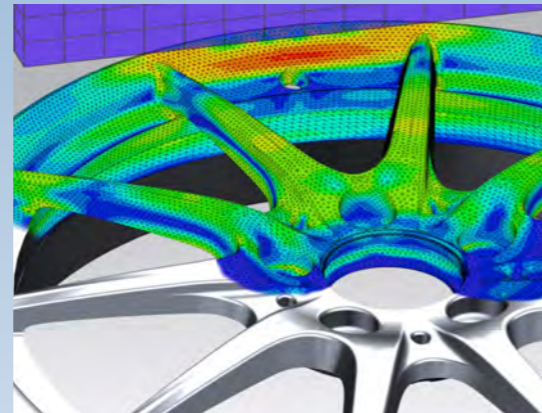

Contact

FHNW Institute of Product and Production Engineering • Klosterzelgstr. 2 • CH - 5210 Windisch •
Tel: +41 (0) 56 202 77 00 • info.ippe.technik@fhnw.ch



Institute for Sensors and Electronic (ISE)

Profile

The ISE is the competence center for sensors with special focus on aerosol technology as well as for microelectronics, signal processing and communication. We support our partners with the execution of research, development and consulting including serial production according to industrial standards. Our interdisciplinary team consists of approximately 35 specialists in electrical engineering and physics, often with extensive industrial experience.

Space competences

- Space Competences
- Classical and Quantum Cryptography
 - Ground Segment for Nanosatellites
 - Communication Technologies
 - High Altitude Balloons
 - Microelectronics for Functionally Safe Communication
 - Aerosols Technology and Sensors



Contact

Prof. Dr. Gerd Simons • Institute for Sensors and Electronics FHNW • Klosterzelgstr. 2 • CH-5210 Windisch •
gerd.simons@fhnw.ch



Segment	Research	Development	Production
Earth Observation			
Life and Physical Sciences			
Satellite-based Applications		✓	
Instruments and Payloads	✓	✓	
Spacecraft and on-board Equipment	✓	✓	
Ground Segment			
Materials and Processes	✓	✓	✓
Structures	✓	✓	
Electronic Components	✓	✓	
Software	✓	✓	
Basic Research for Space Technology	✓	✓	
Small Satellite Activities	✓	✓	

HES-SO

Profile

The HES-SO Engineering and Architecture Faculty has three missions: to provide practical training at tertiary level, to foster applied research and to deliver technical services to private sector partners. The Faculty offers interdisciplinary competences within its 6 schools (over 5,000 students). Its activities are devoted to the realisation of high quality and reliable products and anchored into the regional industrial systems. The HES-SO schools collaborate closely with SMEs, industries and research institutes.

HES-SO at a Glance

HES-SO Engineering and Architecture includes:

- 21'000 students
- 28 schools of higher education in the 7 cantons of Western Switzerland
- 68 Bachelor's and Master's study programs



Hes-so

Haute Ecole Spécialisée
de Suisse occidentale
Fachhochschule Westschweiz
University of Applied Sciences and Arts
Western Switzerland

HES-SO

HES-SO Engineering and Architecture
Rectorat
Route de Moutier 14, CH - 2800 Delémont
Tel: +41 (0) 58 900 00 00
info@hes-so.ch
www.hes-so.ch

Embedded-Computing Systems, HE-arc, Neuchâtel

Profile

Defined as an autonomous system, often in real time, specialising in a specific task and with limited resources, an embedded IT system is built on three main pillars: Hardware, Software and programming, Signal processing and communication. We employ our expertise to optimise the efficiency of industrial processes, develop smart medical systems and address various challenges facing society, such as global water management.

Space competences

- Hardware development
- Embedded Software
- Low Power Embedded Systems
- Communication Systems
- Signal Processing

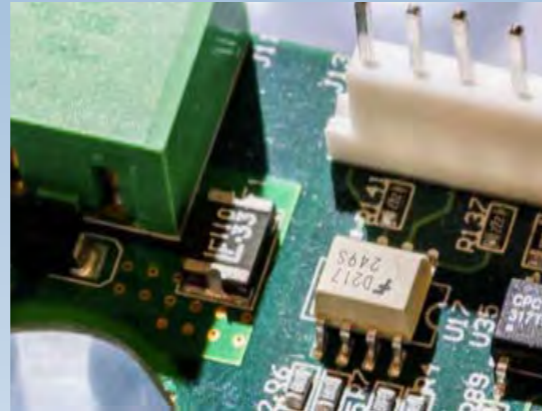

Contact

Dr. Nuria Pazos • Espace de l'Europe 11 • CH - 2000 Neuchâtel • Tel:+41 (0) 32 930 22 50 • nuria.pazos@he-arc.ch



Inst. des Sciences et Technologies Industrielles (inSTI) - Hepia, Geneva

Profile

inSTI is the research Institute of the Industrial Technology Department of the HES-SO / Geneva. Aiming at being a partner of choice in research and development for the local and regional industrial fabric, inSTI develops its R&D activities through technology transfers toward the economy (CTI projects, EU projects, mandates...) on one hand, and through scientific publications and conferences on the other hand.

Space competences

- REXUS rocket based microgravity experiment
- Bioengineering
- Eco-Engineering
- Fluid mechanics applied to the fields of energy
- Materials, nanotechnology and micro-technology designs
- Tribology and robotics

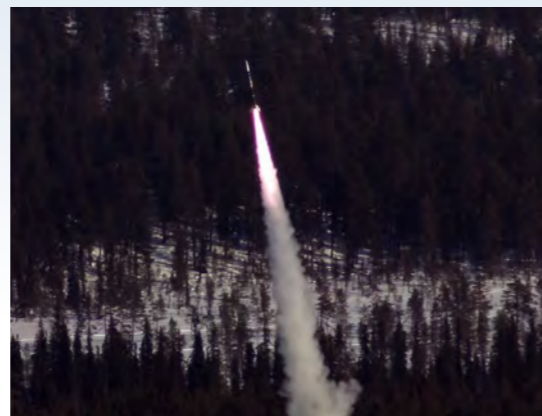

Contact

HES-SO School of Engineering, Architecture and Landscape - Hepia, Geneva • Marc Jacobin • Tel:+41 (0) 22 54 62 659 • marc.jobin@hesge.ch



Institute of Systems Engineering, HEI, Sion

Profile

The focus of the institute is to specify the mechanical dimensions of the building blocks and their connections for CubeSats with their limits in space and power supply. These systems comprise the mechanical housing of the satellite, an On-Board Computer (OBC), the Attitude and Orbital Control System (AOCS), the communication system to the ground and the instruments dedicated to the satellite's mission.

Space competences

- Development of electronic (digital or analog) and mechanic devices used in spacecrafts
- Fulfilment of the requirements in relation to flight electronics: quality, reliability, high performance, good integration, energy efficiency
- Acquisition and processing of low intensity analogical signals • Integration of processors and complex digital functions (IP core)
- Design of actuators using shape-memory alloys



Contact

Prof. F. Corthay • Instrumentation & Control systems • Tel:+41 (0) 27 606 87 57 • francois.corthay@hevs.ch • www.hevs.ch • Prof. E. Carreño-Morelli • Powder Technology & Advanced Materials •

Tel:+41 (0) 27 606 88 37 • efrain.morelli@hevs.ch • www.hevs.ch



Laboratory of Applied NanoSciences (COMATEC-LANS)

Profile

The Laboratory of Applied NanoSciences is specialized in advanced materials engineering and surface micro- and submicrostructure characterization. Its interdisciplinary team of engineers and scientist develops and designs advanced materials and processes for coating, printing, and surface treatment for decorative and functional applications.

Space competences

- Advanced atomic force microscopy, optical profilometry: nano- & microstructure analysis of metals, oxides and polymer surfaces or thin films
- Atmospheric pressure plasma surface treatment
- Pilot tests & feasibility studies for industrial surface treatment, processing, coating, and inkjet printing
- Polymer nanocomposites, nano- and microfiber membranes and filters
- Electrical, optical and wetting properties of materials and surfaces



Contact

Prof. Dr. Silvia Schintke • HEIG-VD/HES-SO Laboratory of Applied NanoSciences, Avenue des Sports 20 • CH - 1401 Yverdon-les-Bains • Tel:+41 (0) 24 557 61 67 • silvia.schintke@heig-vd.ch • www.comatec-lans.ch



Reconfigurable & Embedded Digital Systems, HEIG-VD, Yverdon-les-Bains

Profile

The Reconfigurable and Embedded Digital Systems institute (REDS) has multiple skills in R&D for high performance embedded systems. In this area the team is capable of designing a PCB board, developing the FPGA design and the CPU software (drivers up to the final application), and validating the entire system.

Space competences

- Hardware-oriented Efficient Information Processing
- Software-oriented Heterogeneous Device Support
- Integrated Design of Embedded Systems

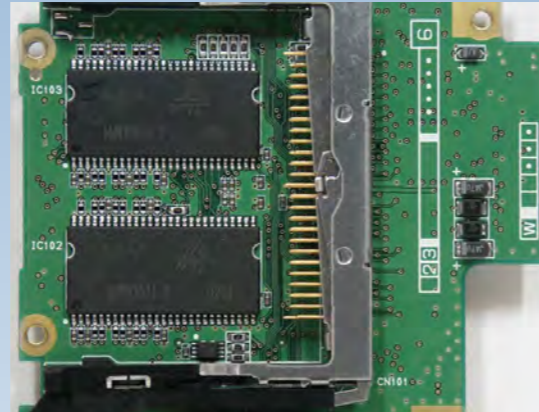

Contact

Yann Thoma • HEIG-VD School of Engineering and Management • Route de Cheseaux 1 • CH - 1400 Yverdon-les-Bains • Tel: +41 (0) 24 557 62 73 • reds@heig-vd.ch • http://reds.ch



HAUTE ÉCOLE
D'INGÉNIERIE ET DE GESTION
DU CANTON DE VAUD
www.heig-vd.ch

ROSAS Center, HEIA-FR, Fribourg

Profile

The Robust and Safe Systems Fribourg (ROSAS) Association, established in June 2015 as a non-profit organization, has the objective to operate the "ROSAS Center Fribourg", a unique in its kind Competence Center for robust, safe, reliable and secure systems. ROSAS is an industry-driven association with members.

Space competences

- Definition of high-level reliability and safety requirements for a future Space Traffic Management System (STM) including space debris, space weather, clean space, hazard and risk assessment and mitigation measures
- Development of a Space Navigation Service Provider (SNSP) Certification Process based on ANSP regulations including the suitability of ground / aircraft CNS equipment for suborbital spaceflights



Contact

Haute Ecole d'ingénierie et d'Architecture Fribourg • ROSAS Center Fribourg • Passage du Cardinal 13B • CH - 1700 Fribourg • Tel: +41 (0) 26 429 67 75 • wolfgang.berns@rosas.center • www.rosas.center

ROSAS
Center Fribourg

Surface Engineering, HE-Arc, Neuchâtel

Profile

Our surface engineering expertise enables us to develop custom solutions and applications. Reflecting the expectations and needs of industrial players, we use our skills to improve and optimise surfaces by working on their design, the choice of materials and their properties.

Space competences

- Surface characterization services
- Surface functionality modification
- Development of "à la carte" solutions
- Surface treatment for decorative and functional purposes



Contact

Dr. Oksana Banakh • Espace de l'Europe 11 • CH - 2000 Neuchâtel • Tel: +41 (0) 32 930 25 20 • Oksana.Banakh@he-arc.ch



Swiss Welding Institute (SWI)

Profile

The center of Sainte-Croix specializes in electronic soldering. Its team will assist you for your certifications, for your trainings in high-reliability or industrial electronic soldering, for the choice of soldering parameters, of soldering process and the implementation of validation tests.

Space competences

- Spatial certifications: Operator ECSS-Q-ST-70-08 Cat. 3 (Hand soldering THT)
- Operator/Inspector ECSS-Q-ST-70-26 Cat. 2/3 (Crimping)
- Operator ECSS-Q-ST-70-28 Cat. 3 (Repair and modification)
- Operator/Inspector ECSS-Q-ST-70-30 Cat. 2/3 (Wrapping)
- Operator ECSS-Q-ST-70-38 Cat. 3 (Hand soldering SMT)
- Inspector ECSS-Q-ST-70-08/38 Cat. 2

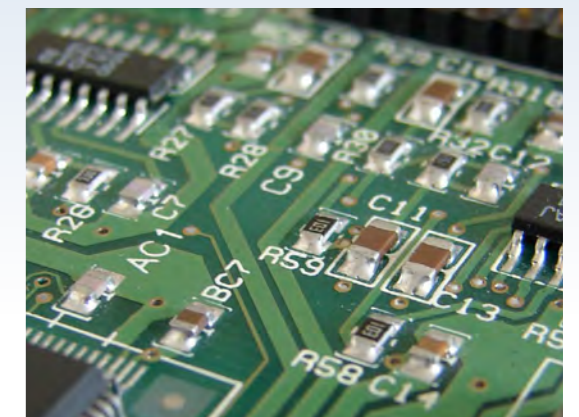

Contact

Pierre Rogé • Swiss Welding Institute • Rue du Nord 3 • CH - 1400 Yverdon-les-Bains • Tel: +41 (0) 24 557 27 90 • pierre.roge@swi.ch • www.swi.ch



Segment	Research	Development	Production
Earth Observation		✓	
Life and Physical Sciences	✓	✓	
Satellite-based Applications		✓	
Instruments and Payloads	✓	✓	✓
Spacecraft and on-board Equipment	✓	✓	
Ground Segment	✓	✓	
Materials and Processes	✓	✓	
Structures	✓	✓	
Electronic Components	✓	✓	
Software	✓	✓	
Basic Research for Space Technology	✓	✓	
Small Satellite Activities	✓	✓	✓

HSLU

Profile

Since 1958, the Lucerne School of Engineering and Architecture has contributed and strengthened Switzerland as a business location by providing bachelor's and master's degree programs, continuing education programs and applied research. With around 2,000 students pursuing bachelor's and master's degrees and almost 1,000 attending continuing education programs, the School is one of the most in-demand institutions in Switzerland. The some 400 researchers organised in 12 competence centers carry out interdisciplinary research on two focal points: "Building as a System" and "Energy for the Future".

HSLU at a Glance

- Bachelor's degree programs in Architecture, Interior Architecture, Civil Engineering, Building Technology, Electrical Engineering, Mechanical Engineering, Business Engineering Innovation, Medical Engineering and Energy Systems Engineering.
- The Center of Continuing Education offers practical and interdisciplinary education and training, from seminars and certificate courses to continuing education programs.

Lucerne University of Applied Sciences and Arts

HOCHSCHULE LUZERN

Engineering and Architecture
FH Zentralschweiz

Lucerne School of Engineering and Architecture

Technikumstrasse 21
CH - 6048 Horw
Tel: +41 (0) 41 349 33 11
technik-architektur@hslu.ch



Biotechnology Space Support Center (BIOTECH)

Profile

BIOTESC acts on behalf of the European Space Agency ESA. It advises scientists who intend to perform biological experiments under zero gravity conditions on board the International Space Station (ISS) in the Columbus space laboratory and supports the astronauts conducting the experiment. BIOTESC provides the biological laboratory of the Competence Center Aerospace Biomedical Science and Technology for experiment flight readiness tests. In addition, it is responsible for the biological laboratory in the Baikonur Cosmodrome, where experiments are prepared for the flight to the ISS.

Contact

BIOTESC • Biotechnology Space Support Center • Lucerne University of Applied Sciences and Arts • Obermattweg 9 • CH - 6052 Hergiswil • Tel: +41 (0) 41 349 36 19 • bernd.rattenbacher@hslu.ch

Space competences

- Triplelux-A and B
- T-Cell Act In Aging
- Stem Cell Differentiation
- Nano – Cytospace
- Endothelial Cells
- Spheroids
- EPO Christoforetti and EPO Peake



CC Electronics

Profile

The Competence Center Electronics (CCE) team has demonstrated core competences in key technology areas such as communication system design, digital and embedded system design, multiphysics simulation and analog electronic circuit design. CCE supports university level space activities as well as space companies mainly in the field of communication systems and ground segment infrastructure for precursor missions.

Contact

Prof. Marcel Joss • Technikumstrasse 21 • CH - 6048 Horw • Tel: +41 (0) 41 349 33 02 • marcel.joss@hslu.ch • www.hslu.ch/electronics

Space competences

- Design and development of rf/microwave communication modules
- Design and development of payload electronics (hardware and firmware)
- Design and development of ground segment infrastructure
- Modeling/analysis of multiphysics systems (acoustics, mechanics, em-waves (rf, optics) and ac/dc thermo-electric systems)

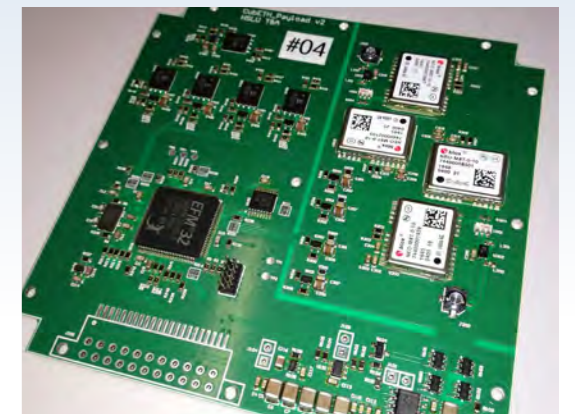

Lucerne University of Applied Sciences and Arts

HOCHSCHULE LUZERN

Engineering and Architecture
FH Zentralschweiz

CC Mechanical Systems

Profile

The Competence Center (CCMS) provides all competences for a holistic and efficient design of mechanical systems, including their design and development up to their manufacturing, assembly and testing. It is specialized on applied research and sophisticated engineering services, including the fields of design, simulation, material and functional testing and prototype generation. The CCMS supports university level space activities and space segment companies.

Space competences

- Design and structural/thermal analysis
- Multi-body analysis
- Materials mechanical testing
- Micro-mechanical testing
- Space mechanisms systems
- Systems engineering
- Zero-g experiment
- Random Positioning Machine
- Mechanism and scientific instruments

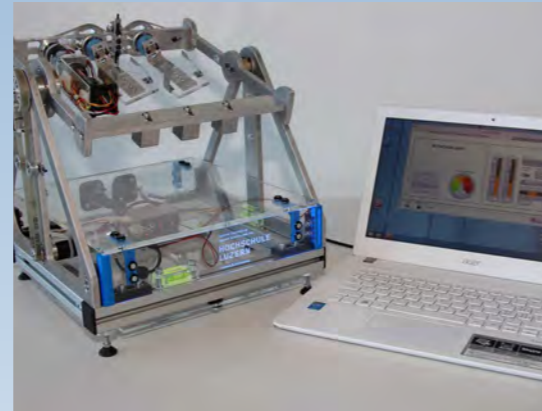

Contact

Prof. Ralf Baumann • Head of Competence Center • Technikumstrasse 21 • CH - 6048 Horw •
Tel: +41 (0) 41 349 32 55 • ralf.baumann@hslu.ch • www.hslu.ch/ccms



Institute of Medical Engineering

Profile

The Institute is conducting biomedical and biotechnological research in the context of space medicine and mechanobiological dysfunction on the earth. Experiments address questions concerning biological mechanisms of mechano-transduction. Research platforms like parabolic flights, sounding rockets or the ISS are used regularly. The Institute also maintains a User Support Center of the European Space Agency.

Space competences

- Support of biological experiments on board the ISS
- Construction of various microgravity simulators
- Construction of space-proven bioreactors
- Construction of space-proven electrophysiological instruments for life cell monitoring
- Enabling real-time microscopy under simulated microgravity conditions
- Facilitating alternative microgravity research platforms



Contact

Prof. Marcel Egli • Institute of Medical Engineering • Seestrasse 41 • CH - 6052 Hergiswil •
Tel: +41 (0) 41 349 36 18 • marcel.egli@hslu.ch •
www.hslu.ch/de-ch/technik-architektur/institute/medizintechnik/



Segment	Research	Development	Production
Earth Observation	✓	✓	
Life and Physical Sciences			
Satellite-based Applications	✓	✓	
Instruments and Payloads	✓	✓	
Spacecraft and on-board Equipment	✓		
Ground Segment	✓	✓	
Materials and Processes			
Structures			
Electronic Components	✓	✓	
Software			
Basic Research for Space Technology	✓		
Small Satellite Activities			

UniNE

Profile

The University of Neuchâtel (UniNE) is an internationally recognized institution, known for its reasonable size and favorable student-teacher ratio. With more than 4300 students from Switzerland and beyond (20% international students), it provides high quality teaching and support and is ranked among the 20 best small universities worldwide. Bachelor and Master's degrees are compatible with most other European universities and are in line with society's expectations in a variety of innovative and cutting-edge fields. Situated halfway between Geneva and Zurich, UniNE is a perfect place for those who wish to study or to undertake high-level research in a magnificent environment, near lake and mountains.

UniNE at a Glance

- 4 faculties: humanities, science, law, economics and business
- >4300 students
- 600 doctoral candidates
- 780 staff members (FTE equivalent)
- >1000 degrees (awarded in 2016)
- >600 research projects



UNI NE
Université de Neuchâtel
Avenue du 1er-Mars 26
CH - 2000 Neuchâtel
Tel: +41 (0) 32 718 10 00
contact@unine.ch
www.unine.ch

The Time and Frequency Laboratory (LTF)

Profile

The mission of LTF is to explore and push the frontiers in time and frequency research, optical metrology, and ultrafast science and technology. In collaboration with METAS, LTF developed the Swiss primary atomic fountain clock FOCS-2. LTF closely collaborates with local and national space actors like EPFL, CSEM, atomic clocks industry, and others.

Space competences

- Time & Frequency metrology
- Ultrafast lasers
- Optical frequency references for atomic clocks and space applications
- High-performance and miniaturized vapour-cell atomic clocks
- Various frequency combs systems
- Stabilization of microwave and optical oscillators
- State-of-the-art ion beam sputtering (IBS) machine for custom optics
- Cold atoms



Contact

Laboratoire Temps-Fréquence • Avenue de Bellevaux 51 • CH - 2000 Neuchâtel • Tel:+41 (0) 32 718 29 00 • Secretariat.Physique@unine.ch



Segment	Research	Development	Production
Earth Observation			
Life and Physical Sciences			
Satellite-based Applications			
Instruments and Payloads		✓	
Spacecraft and on-board Equipment			
Ground Segment			
Materials and Processes			
Structures			
Electronic Components	✓	✓	
Software	✓	✓	
Basic Research for Space Technology			
Small Satellite Activities			

USI

Profile

Università della Svizzera italiana (USI) is a dynamic, young university that is not satisfied in limiting its work to consolidate its achievements, but has resolved to take up the gauntlet of finding new ways of enhancing its attractiveness and of raising its profile on both the Swiss and international level. Today, USI comprises five Faculties, with a student population of 3,000, 65% of which made up of international students from more than 100 different countries. Its taught courses (in Italian and English) cover the whole gamut from Bachelor's to PhD degree programmes.

USI at a Glance

- 2862 students
- 109 full professors
- 47 Institutes and Laboratories
- Budget: 89 MCHF

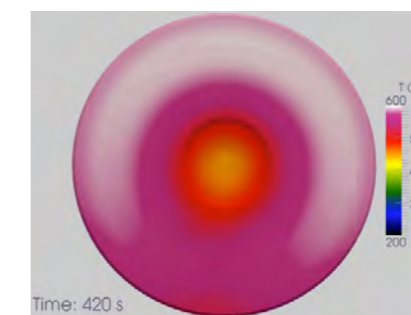
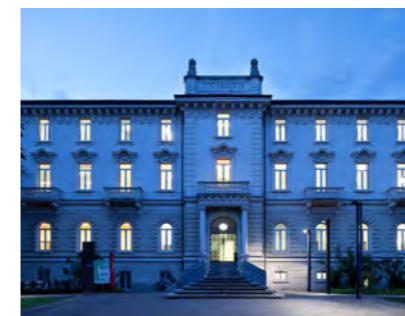

Università della Svizzera italiana

USI

Via Giuseppe Buffi 13
CH - 6904 Lugano
Tel:+41 (0) 58 666 40 00
info@usi.ch
www.usi.ch

Advanced Learning and Research Institute (ALaRI)

Profile

The Advanced Learning and Research Institute (ALaRI) specializes in research and education in cyber-physical and embedded systems. The Institute is an active participant in a number of Swiss and international research endeavors focusing on abstracting real problems, finding solutions and putting them back into practice.

Space competences

- Cyber-physical and embedded systems
- System-level design, modeling and simulation
- Dependability, security and real time
- GNSS instruments
- FPGA-based GNSS fast signal processing
- GNSS software receivers

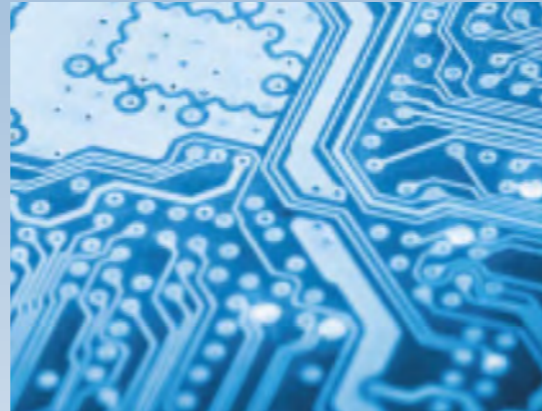

Contact

ALaRI • Università della Svizzera italiana • Via G. Buffi 13 • CH - 6904 Lugano • Tel: +41 (0) 58 666 45 58 • alberto.ferrante@usi.ch • www.alari.ch



Institute of Computational Science (ICS)

Profile

ICS is the largest institute in Switzerland devoted exclusively to computational science. Imbedded into a dense network of national and international cooperation partners, ICS carries out high-level research in computational science in eight research groups with a general focus on life sciences, environmental sciences, economy, and engineering.

Space competences

- Computational Shape Analysis
- Computational Time Series Analysis
- High Performance Methods for Numerical Simulation in Science, Medicine and Engineering
- Medicinal Chemistry & Drug Design
- Advanced Computing Laboratory

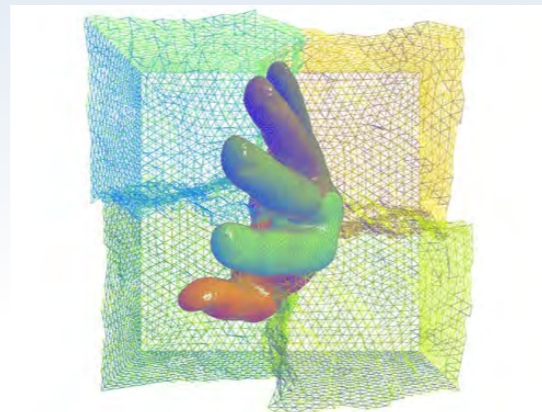

Contact

Institute of Computational Science • Via G. Buffi 13 • CH - 6904 Lugano • Tel: +41 (0) 58 666 43 33 • www.ics.usi.ch



Segment	Research	Development	Production
Earth Observation	✓	✓	✓
Life and Physical Sciences	✓	✓	✓
Satellite-based Applications	✓	✓	✓
Instruments and Payloads	✓	✓	
Spacecraft and on-board Equipment			
Ground Segment	✓	✓	
Materials and Processes		✓	
Structures			
Electronic Components	✓	✓	
Software	✓	✓	✓
Basic Research for Space Technology	✓	✓	
Small Satellite Activities			

UZH

Profile

With its 26,000 enrolled students, the University of Zurich (UZH) is Switzerland's largest university. Founded in the year 1833, UZH was Europe's first university to be established by a democratic political system; today, UZH is one of the foremost universities in the German-speaking world. Made up of seven faculties covering some 100 different subject areas, the University offers a wide variety of Bachelor's, Master's and PhD programs. In addition, UZH's continuing education programs offer excellent learning opportunities.

UZH at a Glance

- Created in 1833
- Largest, most diverse university in Switzerland
- Seven faculties and over 150 institutes
- Four University hospitals
- 26,000 students
- 5000 researchers including 650 professors
- A new patent every two weeks
- A new spin-off every two months
- Two research agreements with industry per day



University of Zurich^{UZH}

UZH
University of Zurich
Rämistrasse 71
CH - 8006 Zurich
Tel: +41 (0) 44 634 11 11
www.uzh.ch

Black Holes and Gravitational Wave Detection

Profile

The groups of Prof. P. Jetzer and Prof. L. Mayer work on gravitational wave experiments, especially on ESA's future Laser Interferometer Space Antenna (LISA). Their research focuses on theoretical and computational modeling of gravitational wave sources and their resulting wave-forms. They are both members of the LISA Consortium. P. Jetzer is also member of the LISA Science Study Team of ESA as well as coordinator of the ESA Topical Team on ACES and General Relativity.

Space competences

- Theoretical and observational astrophysics
- Astrophysical supercomputing simulations
- Gravitational wave research (LISA/LISA pathfinder/LIGO)
- X-ray space telescope (ATHENA)
- Atomic Clock Ensemble in Space (ACES)

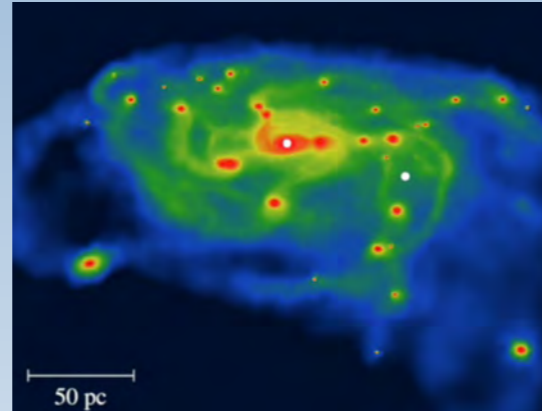

Contact

Prof. P. Jetzer • Physik-Institut • Gravitation and Astrophysics Group • jetzer@physik.uzh.ch • www.physik.uzh.ch/groups/jetzer/

Prof. L. Mayer • Center for Theoretical Astrophysics & Cosmology • Inst. for Computational Science • lmayer@physik.uzh.ch • www.ctac.uzh.ch/research/groups/mayer.html



University of Zurich
UZH

Cell Biology - Gravitational Biology and Biomechanics

Profile

Using parabolic flights, suborbital rocket and International Space Station (ISS) experiments, we investigate the role of gravity in cellular signal transduction, cell dynamics and gene expression regulation in order to understand how gravitational forces contribute to cellular homeostasis and how cells adapt to an altered gravity environment.

Space competences

- Gravitational Biology
- Space Life Sciences
- Manned Spaceflight
- Hardware Design and Development
- Parabolic Flights (incl. Swiss Parabolic Flight program)
- Suborbital Ballistic Rockets
- International Space Station (ISS)



Contact

Prof. Oliver Ullrich • Inst. of Anatomy • Winterthurerstrasse 190 • CH-8057 Zurich • Tel:+41 (0) 44 635 53 10 • oliver.ullrich@uzh.ch • www.anatomy.uzh.ch/en/research/ullrich.html • www.skylab.swiss



University of Zurich
UZH

Glaciology and Geomorphodynamics Group (3G)

Profile

Research of the Glaciology and Geomorphodynamics Group (3G) at the Dept. of Geography has a focus on the cryosphere and high-mountain regions in the context of climate change. We apply modeling, Earth observation data and digital elevation models (DEMs) from a variety of sources for the analysis of related processes, impacts and risks.

Space competences

- Optical remote sensing of glaciers and change assessment
- DEM extraction from stereo images



Contact

Prof. Andreas Vieli • University of Zurich • Department of Geography (GIUZ) • Winterthurerstr. 190 • CH-8057 Zurich • Tel: +41 (0) 44 635 5120 • andreas.vieli@geo.uzh.ch • www.geo.uzh.ch/en/units/3g.html



University of Zurich
UZH

Origin and Evolution of Exoplanets and Solar System

Profile

The group of Prof. R. Helled focuses on astrophysics and planetary science, developing theoretical models for planet formation and evolution, planetary interiors, and the characterisation of exoplanets. Prof. L. Mayer's group focuses on the origin and evolution of protoplanetary disks and on the early stage of planet formation.

Space competences

- Theoretical astrophysics and Planetary Science
- Astrophysical supercomputing simulations
- Exoplanet Detection and Characterisation (PLATO)
- Solar System Exploration (Juno, JUICE)
- Exoplanetary Atmospheres (ARIEL)



Contact

Center for Theoretical Astrophysics & Cosmology • Inst. for Computational Science • Prof. R. Helled • rhelled@physik.uzh.ch • www.ctac.uzh.ch/research/groups/helled.html • Prof. L. Mayer • lmayer@physik.uzh.ch • www.ctac.uzh.ch/research/groups/mayer.html



University of Zurich
UZH

Robotics and Perception Group

Profile

The University of Zurich's Robotics and Perception Group, led by Professor Davide Scaramuzza, specializes in developing autonomous drones that navigate using only onboard cameras. Their research activities are supported by funding from the SNSF, NCCR Robotics, DARPA, and several academic-industrial collaborations, such as KUKA, Qualcomm, Intel, Huawei, and Google.

Space competences

- Computer vision
- Sensor fusion
- Autonomous navigation and exploration
- Localization and mapping
- Motion planning and control
- Machine learning & Deep Neural Networks



Contact

Prof. Davide Scaramuzza • Andreasstrasse 15, 2.10 • CH-8050 Zurich • Tel:+41 (0) 44 635 24 09 • sdavide@ifi.uzh.ch • <http://rpg.ifi.uzh.ch>



Remote Sensing Laboratories

Profile

The Remote Sensing Laboratories (RSL) are embedded in the Department of Geography. RSL's central research goal is to advance understanding of the Earth system sciences using Earth observation methods. We achieve this by combining fundamental and applied research to assess the impact of the human dimension on regional, national and global change.

Space competences

- Imaging spectroscopy, SAR & LiDAR research
- Methods, models, and software development
- Measurement and processing infrastructure
- National and international cooperation
- Policy and stakeholder advice

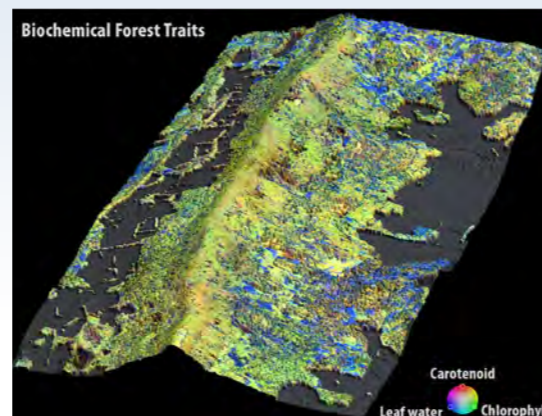

Contact

Prof. Michael Schaepman • Dep. of Geography • Remote Sensing Laboratories • Winterthurerstrasse 190 • CH-8057 Zurich • Tel: +41 (0) 44 635 51 61 • secretary.rsl@geo.uzh.ch • www.geo.uzh.ch/en/units/rsl.html



The Dark Universe

Profile

The astrophysics group is part of ESA's Euclid mission, whose goal is to map our entire observable Universe and get new insights on the nature of dark matter and dark energy. The astroparticle physics group focuses on the direct detection of particle dark matter with dual-phase (liquid and gas) xenon time projection chambers.

Space competences

- Large scale simulations & analyses
- Liquid xenon detectors
- Low-noise and low-background electronics
- Radio-isotope detection with ultra-low background HPGe diodes
- Single-photon detection

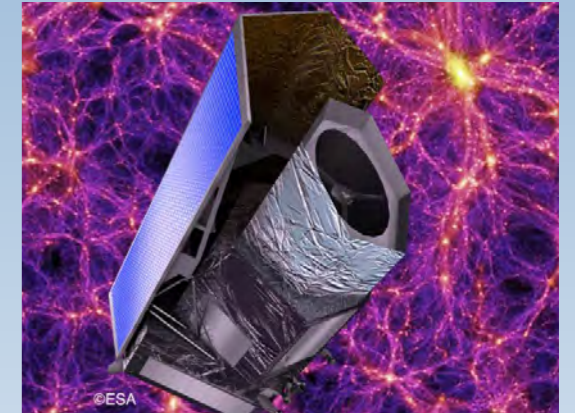

Contact

Prof. R. Teyssier • Inst. for Computational Science • Centre for Theoretical Astrophysics and Cosmology • romain.teyssier@uzh.ch • www.ics.uzh.ch/~teyssier
 Prof. L. Baudis • Physik-Institut • Astroparticle Physics Group • laura.baudis@uzh.ch • <http://www.physik.uzh.ch/en/groups/audis.html>



UZH Space Hub

Profile

The UZH Space Hub is an innovation structure of the University of Zurich to establish collaborative space activities at the Switzerland Innovation Park Zürich at the Dübendorf airport. Today, space represents innovation, inspiration, information, and interaction with many disciplines and players.

Space competences

- Astrophysics
- Earth Observation
- Space Life Sciences
- Infrastructure, e.g. aircraft
- Airborne and spaceborne R&D
- Link academia – industry
- Swiss Parabolic Flights (ZERO-G)
- Access to International Space Station ISS



Contact

Space Hub - Zurich Headquarters • Prof. Dr. Dr. Oliver Ullrich • Winterthurerstrasse 190 • CH-8057 Zurich • Tel:+41 (0) 44 635 53 10 • oliver.ullrich@uzh.ch

Space Hub - Kennedy Space Center Office • University of Zurich Space Hub • Space Life Sciences Laboratory (SLSL) • Kennedy Space Center • STD 190 • 505 Odyssey Way, Exploration Park • FL 32953 • United States of America



Segment	Research	Development	Production
Earth Observation			
Life and Physical Sciences			
Satellite-based Applications			
Instruments and Payloads	✓	✓	
Spacecraft and on-board Equipment			
Ground Segment	✓	✓	
Materials and Processes	✓	✓	
Structures	✓	✓	
Electronic Components	✓	✓	
Software	✓	✓	
Basic Research for Space Technology			
Small Satellite Activities			

ZHAW

Profile

As one of the leading engineering faculties in Switzerland, the ZHAW School of Engineering focuses on topics which will continue to be relevant in future. Our 13 institutes and centres guarantee superior-quality education, continuing professional training, and research and development with an emphasis on the areas of energy, mobility, information and health. The range of study programmes is oriented to the needs of businesses and the economy, and combines scientifically well-founded training as an engineer with a strong practical relevance and an interdisciplinary approach.

ZHAW at a Glance

- ZHAW School of Engineering is one of eight departments of the ZHAW Zurich University of Applied Sciences
- Founded back in 1874 as "Technikum Winterthur"
- 250 lecturers
- 400+ staff members
- 2000+ students (Bachelor and Master degrees)
- 700+ students (Continuing education)
- 13 institutes and centres



ZHAW School of Engineering
 Prof. Marcello Righi
 Technikumstrasse 9, CH - 8400 Winterthur
 Tel: +41 (0) 58 934 67 93
 marcello.righi@zhaw.ch
 www.zhaw.ch



ZHAW: Centre of Aviation

Profile

The Centre for Aviation has strong focus on Aircraft Technologies and Aviation Operations. We are very interdisciplinary with competences from aerodynamics, flight mechanics, system engineering up to human factors and communication. Safety and system reliability are very important but also understanding of space weather is one of our activities.

Space competences

- System Safety, Failure and Hazard Analysis
- Metal Fatigue Investigation for Space Structures or Equipment
- Human Machine Interaction Systems for Control Stations
- Human Factors in Control Room or Space Vehicles



Contact

ZHAW Zürcher Hochschule für Angewandte Wissenschaften • School of Engineering • ZAV Centre for Aviation • Prof. Michel Guillaume • Technikumstrasse 9 • CH - 8400 Winterthur • Tel: +41 (0) 58 934 67 93 • michel.guillaume@zhaw.ch • www.zhaw.ch/zav



ZHAW: Institute of Materials and Process Engineering

Profile

The Institute of Materials and Process Engineering (IMPE) combines competences in materials science and process engineering to develop innovative materials, coatings, processes and equipment. We are a multidisciplinary research center with the goal to bring together basic and applied research in a collaborative environment sharing both their expertise and the most advanced research facilities.

Space competences

- Materials and Process Engineering for:
- Metals
 - Composites
 - Surfaces
 - Coatings
 - Ceramics
 - Adhesives
 - Polymers



Contact

ZHAW School of Engineering • IMPE Institute of Materials and Process Engineering • G. Peikert • Technikumstrasse 9 • P.O. Box • CH - 8401 Winterthur • Tel: +41 (0) 58 934 65 80 • gregor.peikert@zhaw.ch • www.zhaw.ch/impe



ZHAW: Institute of Computational Physics

Profile

For over 20 years, ZHAW's ICP is specialized in the modeling of multi-physics systems, where several physical-chemical phenomena occur simultaneously. Fuel and solar cells are examples of such systems, where electrical, chemical, mechanical, thermal and fluidic phenomena take place. Besides, we maintain a lab for OLED and IR-thermography research.

Space competences

- Development of sensors (MOEMS)
- Development of multiphysics software
- Simulation of electrochemical and photovoltaic cells
- Simulation and testing of organic electronics
- Development of IR thermography instruments

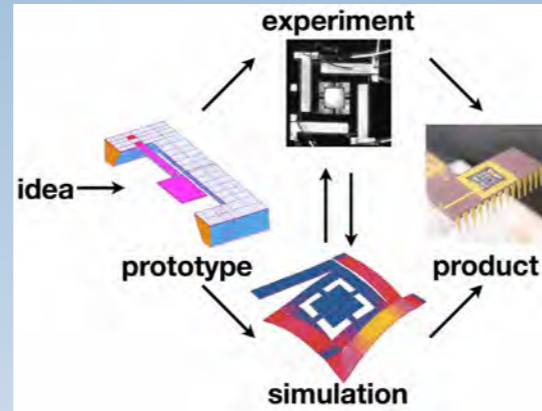

Contact

ZHAW School of Engineering • ICP Institute of Computational Physics • Prof. T. Hocker • Wildbachstrasse 21 • CH - 8400 Winterthur • Tel:+41 (0) 79 630 95 99 • www.zhaw.ch/icp



ZHAW: Institute of Mechanical Systems

Profile

The core competencies of the Institute of Mechanical Systems lie in the area of mechanical structures under heavy mechanical loading. The focus is on the three application areas of biomechanical engineering, lightweight construction engineering and applied mechanics. Components are developed, tested and simulated analytically, numerically and experimentally.

Space competences

- development of lightweight structural components and high-precision mechanisms out of steel, light metal alloys and composites, load path optimization in conjunction with design for additive manufacturing
- numerical and experimental characterization of steady and unsteady inertial, aerodynamic, elastic loads
- numerical and experimental modal analysis, measurement of vibratory level

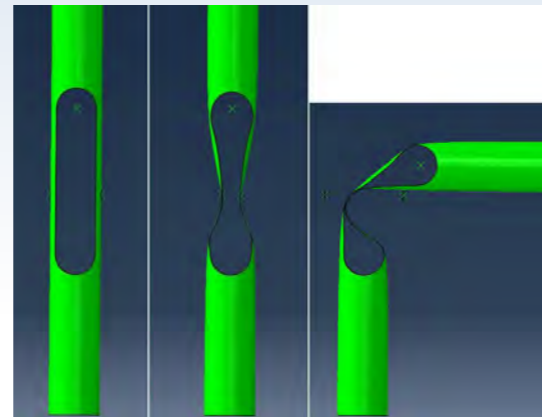

Contact

ZHAW School of Engineering • IMES Inst. of Mechanical Systems • Dr. Robert Eberlein • Head of IMES • Technikumstr. 9, Postfach • CH - 8401 Winterthur • Tel:+41 (0) 58 934 47 28 • robert.eberlein@zhaw.ch • www.zhaw.ch/imes



ZHAW: Institute of Mechatronic Systems

Profile

The Institute of Mechatronic Systems @ ZHAW is active in teaching, advanced vocational training and R&D. The team is made of up to 54 qualified, industry-proven and multidisciplinary professors, experienced engineers, and researchers that carry out applied research and development on a national and international level.

Space competences

- High-precision mechatronic systems
- Electro-optical data transmission
- Advanced control
- Robotics and automation
- Vision and navigation
- System technology



Contact

ZHAW School of Engineering • IMS Inst. of Mechatronic Systems • Prof. H. W. van de Venn • Head of the Inst. of Mechatronic Systems • Technikumstr. 5 • Postfach • CH - 8401 Winterthur • Tel:+41 (0) 58 934 77 89 • wernher.vandevonn@zhaw.ch • www.zhaw.ch/ims • Mechatronik-Cluster Schweiz: www.swiss-mechatronics.ch/



ZHAW Institute of Natural Resource Sciences

Profile

The Institute of Natural Resource Sciences (IUNR) is involved in education, research and development at the intersection between ecological science and engineering. Research and educational activities are destined towards the efficient and sustainable use of natural resources and the conservation of landscapes as natural habitats. We are a team of multidisciplinary researchers in the three thematic fields of a) ecological engineering, b) ecosystems and biodiversity, and c) environmental and agrofood systems.

Space competences

- Closed-Loop-Life-support-systems
- Hydroponic- and aquaponic systems
- Microalgae cultivation & microbiology
- Human and organic waste treatment and -recycling
- Close-range ecological monitoring
- Spatio-temporal analysis and modelling
- UAV-based measurement infrastructure



Contact

ZHAW Life Sciences and Facility Management • Institute of Natural Resource Sciences • Andreas Schönborn • Grüntal 14 • P.O. Box • CH - 8820 Wädenswil • Tel:+41 (0) 58 934 58 10 • andreas.schoenborn@zhaw.ch • www.zhaw.ch/iunr



